

ClayPeople™

FRIENDLY EXPERTS ■ HUGE INVENTORY

CERAMIC SUPPLY EQUIPMENT & PLASTER



CALL US: 510-236-1492
www.ClayPeople.net

Welcome

Contents

Welcome	1
Directions	2
About ClayPeople	3
Clay	4-7
Clay Pricing.....	8-10
Tools	11-27
Brushes.....	28-29
Sprayers & Scales	30
Studio Equipment	31-33
Tile & Adhesives	34
Firing Service	76
Glazes.....	35-57
Mold Making Supplies	58
Banding Wheels	59
Plaster	60
Raw Materials	61-63
Mason Stains®	65-67
Potter's Wheels.....	68-71
Kilns.....	72-75
Kiln Accessories, Parts	77-85
Extruders, Slab Rollers, etc.	86-89
Pug Mills.....	90
Ware Carts	93
Books & Periodicals	92
Index.....	93-95

Greetings ClayPeople!

We are entering our 50th year of serving you!

We are all part of a special timeless family of ClayPeople. This family has a vertical and horizontal axis. The vertical family axis are the ClayPeople who have created with clay through the ages. When archaeologists find human remains, they usually find evidence of pottery.

The horizontal family axis are the ClayPeople who, at any given point in time, are creating in clay around the world. A fascinating variety of ceramic creations exist in all societies.

We work hard to be a strong nexus point in this ClayPeople family continuum: to answer every one of your questions, and find every product you need.

Your ideas and questions always help shape ClayPeople. We are committed to be "Friendly Experts" and to have a "Huge Inventory" of both products and knowledge.

We take great pride in always working to strengthen our position as "Northern California's Leader in Ceramic Supply." Thank for allowing us to be a nexus in your ClayPeople family continuum!

Doug Johnson
President/Owner



ADDRESS

623 South 32nd St.
Richmond, CA 94804

FAX

510- 236-2777

TELEPHONE

510-236-1492

EMAIL

people@claypeople.net

WEBSITE

www.claypeople.net

FACEBOOK

ClayPeople

INSTAGRAM

@claypeoplerichmond

STORE HOURS

Monday - Friday:
9 am - 5 pm
Saturdays: 10 am - 4 pm
Closed: Sundays and
Some Holidays

Prices are subject to change without notice.

Directions

We're right off the freeway near beautiful, historic Point Richmond.



FROM MARIN COUNTY

On 580, EXIT at Regatta Blvd. At first light, turn LEFT onto Regatta/Juliga Woods. Go 3 blocks. Turn left onto S. 32nd St.

FROM BERKELEY/OAKLAND

On 580, EXIT at Regatta Blvd. At stop sign, turn LEFT onto Regatta/Juliga Woods. Go 3 blocks. Turn left onto S. 32nd St.

FROM PINOLE/VALLEJO

On 80, EXIT at Cutting Blvd. At first light, turn RIGHT onto Cutting Blvd. Go 1 mile. Turn LEFT onto S. 31st St. Go 1 block to stop sign. Turn left on Juliga Woods. Go 1 Block. Turn right onto S. 32nd St.

VIA RICHMOND PARKWAY

Take Richmond Parkway to 580 towards Oakland. EXIT at Regatta Blvd. At stop sign, turn LEFT onto Regatta/Juliga Woods. Go 3 blocks. Turn left onto S. 32nd St.

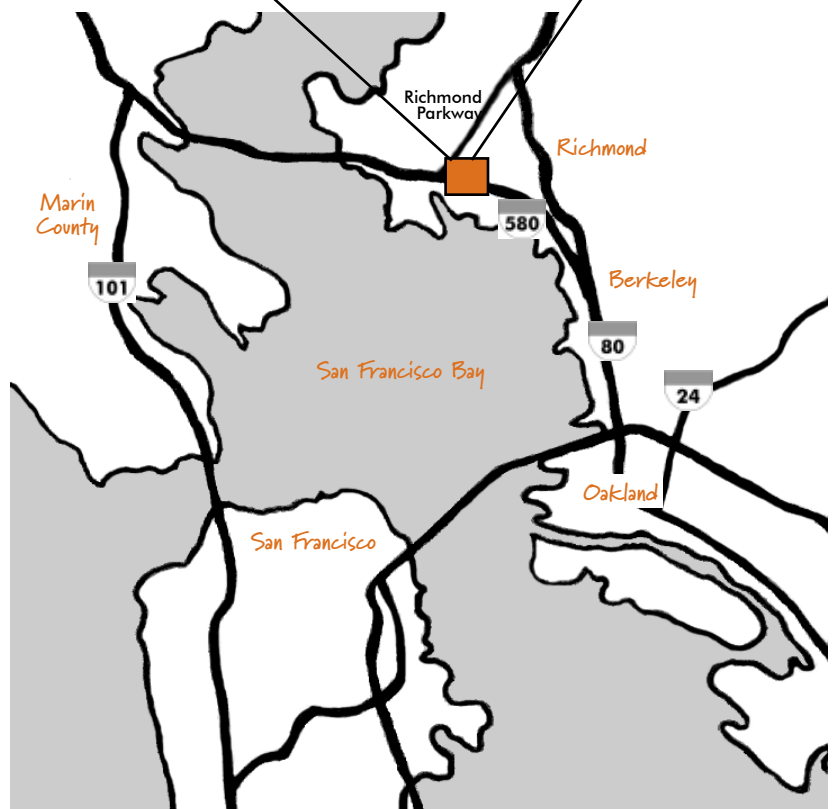

About ClayPeople

GENERAL INFORMATION

ClayPeople is located in Richmond, California. We were founded in 1971. Our customers include schools, businesses, and individual artists, both professional and beginner, throughout the United States. If a product is not in our catalog, we will research it for you. If you have questions, we will get you answers. No order is too small, or too big. Call us. Fax us. Or e-mail us. Please come by our store and visit us.

STORE

Our retail store is currently open 9am - 5pm Monday - Friday, and 10am - 4pm Saturdays. We have a huge in-stock inventory and friendly ceramic experts on hand to answer your questions.

WEBSITE

We are on the web at www.claypeople.net. See the site for a current catalog and specials! Check us out today!

NEWSLETTER

Sign up for our monthly Newsletter online or at the store! You will get information about upcoming sales, and the Clay of the Month!

FACEBOOK & INSTAGRAM

Follow @claypeoplerichmond for secret sales, or be featured yourself! Follow ClayPeople on Facebook to see current sales!



SHIPPING & DELIVERY

We deliver throughout Northern California. We also ship via UPS and USPS. We have discounted rates from truck companies.

FIRING SERVICE

We offer reasonable custom firing rates for customers who do not have access to a kiln. Call ahead and our staff will give you an estimate of turnaround time. See page 76 for an overview of firing rates.

GIFT CARDS

ClayPeople offers gift cards for that special potter or sculptor in your life. These refillable cards offer a convenient way to shop for ceramic supplies.

Say you care with clay!



Clay

Low Fire Clay

EM-207 LOW FIRE RED/Laguna Δ06

Oxidation: Red
Texture: Smooth **Shrinkage:** 6%
Remarks: Comparable in texture and working properties to EM-210. Good for terracotta work.

EM-210 LOW FIRE WHITE/Laguna Δ06

Oxidation: White
Texture: Smooth **Shrinkage:** 5.5%
Remarks: Smooth, all-purpose clay for small hand or wheel work. Works well with cast pieces. An excellent body for teaching beginning techniques such as coil & slab construction.

MEXO RED & MEXO WHITE (WC-640 & 641)

Laguna Air Dry
DRIES: Red and White, respectively
Texture: Med. Coarse **Shrinkage:** 6%
Remarks: Air-dry clay. Safe, multi-purpose and economical, for modeling, throwing, sculpting.

RED SCULPTURE (EM-234)/Laguna Δ06

Oxidation: White **Reduction:** N/A
Texture: Coarse **Shrinkage:** 4%
Remarks: Red sculpture body for large items where variation in wall thickness is a concern. Ideal for handbuilding, murals, columns. Minimal warping, shrinking or cracking.

TIJUANA RED/IMCO Δ04-5

Oxidation: Cone 04 Deep warm; dark chocolate brown at Cone 5. Can be fired LOW and MID.
Texture: Smooth **Shrinkage:** 7.5%
Remarks: Terracotta clay body containing fine grog, giving it strength for building or throwing large pottery. Excellent for burnishing.



Moist Clays are sold in 25 lb. plastic bags. When choosing a clay body there are numerous factors to consider, including color, plasticity, porosity, texture, vitrification, firing temperatures, and glaze fit. Refer to each clay description for specific information and ask us to help match clays with your needs.

See pages 8-10 for complete clay pricing.

Mid Fire Clay

B-3 BROWN (WC-391)/Laguna Δ5

Texture: Slightly Coarse **Shrinkage:** 10%
Oxidation/Reduction: Red/Brown
Remarks: Pliable clay with smooth grog and color from manganese and iron. Fires almost black in oxidation. Do not fire this clay in reduction.

B-MIX CONE 5 (WC-401)/Laguna Δ5

Texture: Smooth **Shrinkage:** 12%
Oxidation/Reduction: Cream/Off-White-Gray
Remarks: A creamy white clay, excellent glaze results. Very plastic with smooth porcelain texture. Dry slowly to avoid cracking.

B-MIX CONE 5 GROG (WC-436)/Laguna Δ5

Texture: Slightly Coarse **Shrinkage:** 11%
Oxidation/Reduction: Off-White/Gray-White
Remarks: Same as Cone 5 B-Mix with fine grog for strength. Avoids speckling of Cone 5 B-Mix w/ Sand.

B-MIX CONE 5 SAND (S-2203)/Laguna Δ5

Texture: Slightly Coarse **Shrinkage:** 12%
Oxidation/Reduction: Cream/Off-White
Remarks: Same as B-Mix with 10% fine 90 mesh silica sand for texture and more strength.

B-MIX CONE 5 SPECKLES (WC-408)/Laguna Δ5

Texture: Slightly Coarse **Shrinkage:** 12.5%
Oxidation/Reduction: Warm speckled white
Remarks: Same working properties as B Mix WC-401. Smooth, porcelain stoneware that is very plastic and workable. Slow drying and ample compression on rims and bottoms to avoid cracks.

BUFF SCULPTURE (WC-392)/Laguna Δ5

Texture: Coarse **Shrinkage:** 5%
Oxidation/Reduction: Buff/Dark Tan
Remarks: Excellent coarse sculptural body with 60 mesh sand and 30-60 mesh grog. Nice range of firing colors and low shrinkage.

CALICO (WC-871)/Laguna Δ5

Texture: Medium Coarse **Shrinkage:** 13%
Oxidation/Reduction: Speckled Gray-Buff/Gray-Tan
Remarks: General-purpose clay that works well in all forming methods. 60m sand adds medium texture. Gives a speckled reduction look in electric kiln.

CHARCOAL/Aardvark Δ5-6

Texture: Medium Coarse **Shrinkage:** 13%
Oxidation: Very Dark Brown
Remarks: a medium grit black body without the issues of bloating! Works well with most glazes and provides a beautiful black base for decoration.

DIXON/Aardvark Δ5

Texture: Very Coarse **Shrinkage:** 8%
Oxidation/Reduction: Rust Brown/Dark Brown
Remarks: A strong grogged clay body great for hand building and sculpture. Not for the wheel.

Mid Fire Clay, cont

DOVER WHITE (D60/WC-877)/Laguna Δ5
Texture: Slightly Coarse **Shrinkage:** 11%
Oxidation/Reduction: Off-White/Gray-White
Remarks: Stoneware that is excellent for dinnerware and large scale work. Has 60 mesh sand for strength.

DRAGON FRUIT/IMCO Δ6
Texture: Slightly Coarse **Shrinkage:** 13%
Oxidation/Reduction: Off-White/Gray-White
Remarks: SDragon Fruit is a unique cone 6 Clay body. Designed for throwing, and the specks create an intriguing visual treat. Not recommended for Reduction

ELECTRIC BROWN (WC-866)/Laguna Δ5
Texture: Slightly Coarse **Shrinkage:** 13%
Oxidation/Reduction: Brown/Warm Brown
Remarks: Designed specifically for warm color in oxidation. Good for throwing or handbuilding.

GRANITE/East Bay Clay Δ5
 Clay produced by East Bay Clay, grey with speckles.

HALF & HALF (WC-402)/Laguna Δ5
Texture: Slightly Coarse **Shrinkage:** 13%
Oxidation/Reduction: Off-White/Light Gray/White
Remarks: The Cone 5 answer to Laguna's Cone 10 Half & Half. Equal amounts of white stoneware and porcelain, is a very throwable white body.

HAWAIIAN RED (WC-365)/Laguna Δ5
Texture: Slightly Coarse **Shrinkage:** 10.5%
Oxidation/Reduction: Red Brown/Dk. Red Brown
Remarks: A red clay with excellent properties for wheel throwing and handbuilding. Talc-free with sand, suitable for medium sized forms.

LB6 (WC-393)/Laguna Δ6
Texture: Medium Coarse **Shrinkage:** 10%
Oxidation/Reduction: Gray Brown/Light Gray
Remarks: A Long Beach type body with 60 mesh sand and color provided by manganese dioxide.

MOROCCAN SAND (WC-400)/Laguna Δ5
Texture: Smooth **Shrinkage:** 12%
Oxidation/Reduction: Sand/Lt. Brown
Remarks: Quite vitreous, ideal for throwing functional ware.

OBSIDIAN (CASSIUS)/Aardvark Δ5
Texture: Smooth **Shrinkage:** 14.5%
Oxidation/Reduction: Black/Not for Reduction
Remarks: Very black ebony-like finish. Satin smooth. High iron content. Bloats over cone 5!

PAPEL PORCELAIN CLAY PAPER/Aardvark Δ5
Texture: Smooth **Shrinkage:** 12%
Oxidation/Reduction: White
Remarks: Based on Nara Porcelain. Great for hand building. When fired, paper burns out creating a lighter piece. Creates stronger greenware and less shrinkage.

RED VELVET (AKA NAVAJO WHEEL)/IMCO Δ6
Texture: Smooth **Shrinkage:** 15%
Oxidation/Reduction: Reddish Brown/Charcoal
Remarks: Excellent smooth, plastic red clay for hand and wheel work where deep red tile color is desired. Good for pit firing.

SEDONA RED/Aardvark Δ5
Texture: Slightly Coarse **Shrinkage:** 11.5%
Oxidation/Reduction: Red Brown/Very Dark Brown
Remarks: Red body. Quite smooth. Great throwing clay.

SPECKLED BUFF (WC-403)/Laguna Δ5
Texture: Slightly Coarse **Shrinkage:** 12%
Oxidation/Reduction: Buff with Specks/Brown with Specks
Remarks: Low in sand and grog content, it is smooth, excellent for throwing.

STONEWARE I-C/IMCO Δ6
Texture: Slightly Coarse **Shrinkage:** 11.8%
Oxidation/Reduction: Sandstone/Brown
Remarks: Contains fine silica sand for a smooth texture and a vitreous stoneware body at cone 5. Looks like cone 10 reduction at cone 5 in oxidation!

TERRA RED/Aardvark Δ5
Texture: Slightly Coarse **Shrinkage:** 12.5%
Oxidation/Reduction: Red Brown/Very Dark Brown
Remarks: While the clay is coarse, it feels smooth while throwing or hand building. Nice blend of color, tooth and workability.

TOKI FLAMEWARE (WC-440)/Laguna Δ5
Texture: Smooth **Shrinkage:** n/a
Oxidation/Reduction: Light Brown/Dark Brown
Remarks: Formulated to resist the shock of an open flame; exceptional heat retaining properties. Great for gas/electric ranges, ovens, broilers, barbeques, & microwaves. Fire to cone 5 for optimal shock resistance.

Clay

High Fire Clay

- 8-11 BUFF 35/IMCO** Δ10
Texture: Slightly Coarse
Shrinkage: 12% **Oxidation/Reduction:** Lt. Gray-Cream/Speckled Grey Buff
Remarks: Versatile throwing clay with fine grog, excellent plasticity and green strength. Good drying characteristics. Great thermal shock resistance.
- 8-11 RED 35/IMCO** Δ10
Texture: Slightly Coarse **Shrinkage:** 12.5%
Oxidation/Reduction: Buff Gray/Toasted Red
Remarks: Has 35 mesh refractory grog, giving versatile body with great strength. Great thermal shock resistance.
- BLACK MOUNTAIN/Aardvark** Δ10
Texture: Slightly Coarse **Shrinkage:** 12%
Oxidation/Reduction: Chocolate-Brown/Brown-Black
Remarks: A deep brown/black clay. Medium texture. Great for wheel. Warm chocolate brown in oxidation. Rich brown to black in reduction.
- BLACK MOUNTAIN SCULPTURE/Aardvark** Δ10
Texture: Medium Coarse **Shrinkage:** 8%
Oxidation/Reduction: Chocolate-Brown/Brown-Black
Remarks: Same as Black Mountain regular with grog added for sculptural strength.
- B-MIX 10 (WC-379)/Laguna** Δ10
Texture: Smooth **Shrinkage:** 13%
Oxidation/Reduction: Off-White/Gray-White
Remarks: A plastic clay that is easy to throw and form. Smooth porcelain texture. Excellent glaze results. Fires grey in reduction, white in oxidation. Dry slowly to avoid cracking.
- B-MIX 10 W/ GROG (WC-893)/Laguna** Δ10
Texture: Slightly Coarse **Shrinkage:** 10.3%
Oxidation/Reduction: Off-White/Gray-White
Remarks: Same as B-Mix with fine grog added for strength. Avoids speckling of B-Mix w/Sand.
- B-MIX 10 W/ SAND (WC-380)/Laguna** Δ10
Texture: Slightly Coarse **Shrinkage:** 12%
Oxidation/Reduction: Off-White/Gray-White
Remarks: The addition of 10% fine, 90 mesh silica sand allows for a body with some texture. Some speckling may occur.
- CARMEL/Aardvark** Δ10
Texture: Medium Coarse **Shrinkage:** 10%
Oxidation/Reduction: Dark Brown/Black
Remarks: Rich brown-black clay. Excellent throwing qualities.
- DARK BROWN (WC-373)/Laguna** Δ10
Texture: Medium Coarse **Shrinkage:** 12.5%
Oxidation/Reduction: Brown/Deep Brown
Remarks: A medium coarse, dark clay with 60 mesh sand. Good for various forming techniques.
- DEATH VALLEY RED (WC-835)/Laguna** Δ10
Texture: Medium Coarse **Shrinkage:** 12.5%
Oxidation/Reduction: Orange-Brn/Dark Brn **Remarks:** Fires to a dark brown color with iron specks. Good for general use.
- GROGZILLA/Clay Planet** Δ10
Texture: Coarse **Shrinkage:** 9.5%
Oxidation/Reduction: Buff/Light Toast **Remarks:** A specialty sculpture body with hellmer kaolin, 4 types of grog, heavy sand and feldspar inclusions. Great for wood, soda and salt firings.
- HBCA (WC-427)/Laguna** Δ10
Texture: Coarse **Shrinkage:** 12.5%
Oxidation/Reduction: Yellow-orange/Orange-brown
Remarks: Has best qualities of California and Missouri fireclays. Excellent throwing stoneware. A very plastic body which is orange-brown with slight speckling in reduction.
- LONG BEACH (WC-376)//Laguna** Δ10
Texture: Medium Coarse **Shrinkage:** 10%
Oxidation/Reduction: Dark Brown/Black
Remarks: A fluid throwing clay, good for throwing small to large. Formula includes iron & 60 mesh sand.
- PAPER CLAY IVORY/IMCO** Δ10
Texture: Medium Coarse **Shrinkage:** 12%
Oxidation/Reduction: Buff/Medium Brown
Remarks: Sculpture 412 clay body with paper fiber added. Great for coils, slabs and sculpture. Wet clay can be attached to dry greenware and even bisque.
- ROD'S BOD/Laguna** Δ10
Texture: Medium Coarse **Shrinkage:** 14.0%
Oxidation/Reduction: Yellow-Buff/Medium Brown
Remarks: Medium sand texture. Good for general use.
- SCULPTURE MIX 412/IMCO** Δ10
Texture: Medium Coarse **Shrinkage:** 11%
Oxidation/Reduction: Soft Buff/Toast-Tan
Remarks: Same rugged qualities as Sculpture Mix 513. A finer mesh grog has been substituted for a smoother texture. All purpose sculpting, throwing, and raku body.
- SCULPTURE MIX 513/IMCO** Δ10
Texture: Very Coarse **Shrinkage:** 13%
Oxidation/Reduction: Buff/Toast-Tan
Remarks: Very plastic durable body with high percentage of refractory 20 mesh grog for rugged strength from wet work through final firing. Excellent for slab building, small to large sculpture and Raku.
- SCULPTURE RAKU/Clay Planet** Δ05-10
Texture: Medium Coarse **Shrinkage:** 6-9%
Oxidation/Reduction: Buff/Tan
Remarks: Designed for the extreme demands of raku, throwing & sculptural work. Plastic and strong. High sand and grog content. Withstands thermal shock well.
- SMOOTH SCULPTURE MIX/Clay Planet** Δ10
Texture: Smooth **Shrinkage:** 13.5%
Oxidation/Reduction: Off White
Remarks: 200 mesh Mullite & Kyanite creates smooth clay for sculpting, with lower shrinkage, and greater warp/crack resistance. Also throws well.

High Fire Clay, cont.

SOLDATE 60 (WC-843)/Laguna $\Delta 10$
Texture: Medium Coarse **Shrinkage:** 13.5%
Oxidation/Reduction: Yellow-Buff/Yellow-Brown
Remarks: Soldate 30 with finer 60 mesh sand for smoother texture.

SONORA WHITE/Aardvark $\Delta 10$
Texture: Coarse **Shrinkage:** 11%
Oxidation/Reduction: White/Off-white to light tan
Remarks: White throwing clay with 60 mesh sand. Speckled grey and white surface in heavy reduction. Excellent for functional ware.

WSO (WC-389)/Laguna $\Delta 10+$
Texture: Slightly Coarse **Shrinkage:** 10%
Oxidation/Reduction: Off-White/Gray-White
Remarks: Contains fine sand. Good for raku. Slightly open body at cone 10.

Porcelain Mid Fire

FROST CONE 5 (WC-437) /Laguna $\Delta 5$
Texture: Smooth **Shrinkage:** 10:14%,
Oxidation/Reduction: Pure White/Light Gray
Remarks: Years in development, this clay is pure white and translucent. Very translucent medium range or high fire porcelain.

HAGI PORCELAIN WC-861/Laguna $\Delta 5$
Texture: Smooth **Shrinkage:** 8.5%
Oxidation/Reduction: White/Off white
Remarks: Good for throwing small and handbuilding.

NARA 5/Aardvark $\Delta 5$
Texture: Smooth **Shrinkage:** 12%
Oxidation: White
Remarks: Excellent porcelain body. Like an English grolleg body at a very reasonable price.

PORCELAIN FIVE (WC-395)/Laguna $\Delta 3-5$
Texture: Smooth **Shrinkage:** 13.0%
Oxidation/Reduction: Off-White/Gray
Remarks: Smooth, very good throwing, vitreous porcelain. Excellent results with gas or electric firing.

PORCELAIN CONE 6/IMCO $\Delta 6$
Texture: Smooth **Shrinkage:** 14.0%
Oxidation/Reduction: White/Light Gray
Remarks: Smooth porcelain body with strength. Slightly translucent at cone 6 oxidation.

WC-617/Laguna $\Delta 6$
Texture: Smooth **Shrinkage:** 14%
Oxidation/Reduction: White/N/A
Remarks: Grolleg porcelain. Less white due to more ball clay, but more plastic and forgiving. Silica reduces crazing in some glazes. Good for slab work.

Porcelain High Fire

BABU (WC-428)/Laguna $\Delta 10$
Texture: Smooth **Shrinkage:** 15%
Oxidation/Reduction: White/White
Remarks: A grolleg porcelain. Very white in oxidation. Good for dinnerware.

COLEMAN PORCELAIN/Aardvark $\Delta 10$
Texture: Smooth **Shrinkage:** 11%
Oxidation/Reduction: White/White to Light Gray
Remarks: Grolleg body developed by Tom Coleman. Best domestically produced porcelain, and very white and translucent. Great for wheel thrown pieces of all sizes.

DAVE'S PORCELAIN (WC-384)/Laguna $\Delta 10$
Texture: Smooth **Shrinkage:** 13%
Oxidation/Reduction: Off-White/Light Gray
Remarks: An outstanding throwing body. Ideal for thin walls and larger pieces and excellent for slab use when a vitreous clay is desirable.

NARA 10/Aardvark $\Delta 10$
Texture: Smooth **Shrinkage:** 12%
Oxidation: White
Remarks: Excellent porcelain body. Like an English grolleg body at a very reasonable price.

550 PORCELAIN (WC-631)/Laguna $\Delta 10$
Texture: Smooth **Shrinkage:** 15%
Oxidation/Reduction: White
 Mostly English Grolleg. Plasticizers for very translucent results. Good for all uses.



Clay Pricing

Low Fire Clay

Prices are per 25 lb. bag!
Please combine clays for
volume discounts.

CODE	CLAY	Cone	25#	100	500	1k#	2k#
EM207	Low Fire Red	04	25.75	24.43	22.13	18.58	15.93
EM210	Low Fire White	04	26.75	24.33	20.43	17.50	15.08
MEXOW	MEXO White (WC-641)	AIR	42.70	38.83	32.60	27.95	24.08
MEXOR	MEXO Red (WC-640)	AIR	42.83	38.95	32.70	28.03	24.90
RS	Red Sculpture (EM-234)	04	26.68	24.25	20.38	17.45	15.03
TR	Tijuana Red	04	25.75	24.43	22.13	18.58	15.93

Mid Fire Clay

Prices are per 25 lb. bag! Please combine clays for
volume discounts.

CODE	Clay	Cone	25#	100#	500#	1k#	2k#
B3B	B-3 Brown (WC-391)	MF	30.68	27.88	23.43	20.08	17.28
BM5	B-MIX 5 (WC-401)	MF	24.13	21.95	18.43	15.80	13.60
BM5G	B-MIX 5 w/Grog (WC-436)	MF	25.65	23.33	19.58	16.78	14.45
BM5S	B-MIX 5 w/Sand (S-2203)	MF	25.50	23.20	19.48	16.70	14.38
BM5SPK	B-Mix 5 Speckles (WC-408)	MF	28.25	25.70	21.58	18.50	15.93
BS	Buff Sculpture (WC-392)	MF	25.38	23.08	19.38	16.60	14.30
CAL	Calico (WC-871)	MF	18.30	16.63	13.98	11.98	10.30
CHAR	Charcoal	MF	26.88	24.48	21.12	18.24	15.36
DIX	Dixon Sculpture	MF	29.70	27.00	22.46	19.44	16.74
D60	Dover White (WC-877)	MF	24.95	22.70	19.05	16.33	14.08
DF	Dragon Fruit	MF	34.75	32.00	28.00	22.75	20.75
EB	Electric Brown (WC-866)	MF	29.30	26.63	22.38	19.18	16.50
GRANITE	Granite	MF	29.75	27.00	22.50	n/a	n/a
HH	Half & Half (WC-402)	MF	24.08	21.88	18.38	15.75	13.58
HR	Hawaiian Red (WC-365)	MF	24.13	21.95	18.43	15.80	13.60
LB6	LB 6 (WC-393)	MF	17.95	16.33	13.70	11.75	10.13
MS	Moroccan Sand (WC-400)	MF	25.10	22.83	19.18	16.43	14.15

Clay Pricing

Mid Fire Clay, cont.

Prices are per 25 lb. bag! Please combine clays for volume discounts.

CODE	Clay	Cone	25#	100#	500#	1k#	2k#
O	Obsidian (aka. Cassius)	MF	35.65	31.68	27.33	23.75	20.33
PAPEL	Papel Paper Clay ^5	MF	33.00	28.80	24.96	21.60	18.60
RV	Red Velvet (aka. Navajo)	MF	19.00	17.25	14.50	11.75	10.75
SER	Sedona Red	MF	18.70	17.00	14.28	12.31	10.54
SPKB	Speckled Buff (WC-403)	MF	23.10	21.00	17.65	15.13	13.03
S1C	Stoneware 1C	MF	18.25	16.50	14.00	11.50	10.25
TER	Terra Red	MF	20.35	18.50	15.17	13.39	11.47
TOKI	Toki Flameware (WC-440)	MF	88.15	80.13	67.30	57.70	49.68

High Fire Clay

CODE	Clay	Cone	25#	100#	500#	1k#	2k#
811B	8-11 Buff 35	11	20.25	18.50	15.50	12.50	11.50
811R	8-11 Red 35	10	20.25	18.50	15.50	12.50	11.50
BMT	Black Mountain	10	18.03	16.50	13.65	11.88	10.43
BMTS	Black Mountain Sculpture	10	20.90	19.00	15.96	13.68	12.01
BM10	B-Mix 10 (WC-379)	10	22.15	20.13	16.90	14.50	12.48
BM10G	B-Mix 10 w/Grog (WC-893)	10	26.40	24.00	20.15	17.28	14.88
BM10S	B-Mix 10 w/Sand (WC-380)	10	24.13	21.95	18.43	15.80	13.60
CAR	Carmel (aka. Jamaica)	10	20.35	18.50	15.17	13.32	11.47
DB	Dark Brown (WC-373)	10	20.70	18.83	15.80	13.55	11.68
DV	Death Valley Red (WC-835)	11	20.90	19.00	15.95	13.68	11.78
GZ	Grogzilla	10	22.80	18.62	16.15	15.20	13.78
HBCA	HBCA SPEC. 7-10 (WC-427)	10	25.10	22.83	19.18	16.43	14.15
LONG	Long Beach Clay	10	17.60	16.00	13.31	11.52	9.92
PCI	Paper Clay Ivory 10	10	29.50	27.25	24.00	19.25	17.75
RB	Rod's Bod (WC-823)	10	17.75	16.13	13.55	11.60	10.00
S412	Sculpture Mix 412	10	24.50	22.25	18.75	15.00	13.75
S513	Sculpture Mix 513	10	23.75	21.50	18.00	14.75	13.25
SR	Sculpture Raku	10	14.40	11.76	10.20	9.60	8.70
SSC	Smooth Sculpture Mix	10	22.20	18.13	15.73	14.80	13.41
S60	Soldate-60 (WC-843)	10	17.25	15.70	13.18	11.30	9.73
SON	Sonora White 60	10	18.70	17.00	14.08	12.38	10.61
WSO	WSO (WC-389)	10	24.55	22.33	18.75	16.08	13.83

Clay Pricing & All Slips

Porcelain

Prices are per 25 lb. Bag! Combine clays for volume discounts.

CODE	Clay	Cone	25#	100#	500#	1k#	2k#
F5	Frost 5-6 (WC-437)	5	43.25	39.33	33.03	28.30	24.38
HP	Hagi Porcelain (WC-861)	5	29.70	27.00	22.68	19.45	16.75
N5	Nara 5	5	33.00	30.00	24.96	21.60	18.60
P5	Porcelain Five (WC-395)	5	24.00	21.83	18.33	15.70	13.53
P6	Porcelain Cone 6	5	37.50	34.50	30.25	24.50	17.50
WC617	WC617 ^ 5 Porcelain	5	39.60	36.00	30.25	25.93	22.33
BP	Babu 10 (WC-428)	5	44.70	40.63	34.13	29.25	25.20
CP	Coleman Porcelain 10	10	41.25	37.50	31.20	27.00	23.40
DP	Dave's Porcelain 10 (WC-384)	10	25.30	23.00	19.33	16.55	14.25
N10	Nara 10	10	27.50	24.00	20.80	18.00	15.50
WC631	#550 Porcelain (WC-631)	10	42.98	39.08	32.83	28.13	24.23

Casting Slips and Slip Additives

B-MIX CONE 5 Δ5
This is the slip version of Cone 5 B-Mix throwing clay. Fires to a cream color. Delivers excellent glaze results.

MOROCCAN SAND Δ5
Light brown casting slip. Semi-vitreous at cone 5. Fires well in both gas and electric kilns.

PEARL Δ6
Fine cone 6 porcelain, highly castable and translucent.

SPECKSTONE Δ10
Stoneware specifically formulated for slip casting. Fires to grayish-white in oxidation and a medium gray-brown in reduction.

TOSHI Δ10
A smooth white porcelain which has been formulated for casting. Can be cast in all standard molds. Fires white in oxidation and eggshell in reduction.

WHITE STAR Δ06-04
An all-purpose casting clay with excellent plasticity. This casting slip clay produces strong greenware and fires white. Works well with most low fire glazes. Fire Cone 06-04.

VISCOMETER
This is an instrument that is a must for proper slip mixing. It measures the viscosity of 500 ml. of slip. Full instructions for use are included.
VISC \$49.95

DARVAN #7

A deflocculant with a wider deflocculation curve. Does not deteriorate molds as actively as sodium silicate.

Pint **\$7.99**
Quart **\$12.99**
Gallon **\$45.00**

SODIUM SILICATE

Used as a major deflocculant in preparing slip. It reduces the amount of water needed, therefore reducing shrinkage.

SOD44oz. \$3.99
SODP Pt. \$5.99
SODQ Qt. \$10.99
SODG Gal. \$19.99



Wet Slip Pricing

Prices are per gallon.
Combine for volume discount.
Speckstone 5 gal is special order only.

Slip	Cone	1 Gal	5 Gal
White Star	06-04	16.01	N/A
BMix 5	5	20.61	92.98
Moroccan Sand	5	19.54	87.95
Pearl	6	23.16	104.99
Snow	5	20.24	N/A
Stoneware S965	5	17.09	76.43
Toshi Porcelain	6	19.88	89.55
Speckstone	10	19.27	-

Dry Slip Pricing

Prices are per bag. Combine for volume discount.

Slip	Cone	50#	100#	500#
Stoneware S965	5	\$37.40	\$36.00	\$33.50
Moroccan Sand	5	\$43.00	\$38.00	\$35.00
Bmix 5	5	\$52.55	\$45.40	\$40.60
Bmix 10	5	\$48.60	\$42.00	\$37.55
Pearl	5	\$57.60	\$49.75	\$44.50
Toshi Porcelain	10	\$47.92	\$41.38	\$37.03
White Star	0-04	\$41.40	\$39.05	\$30.20

Kemper Tools

CLEANUP

Although cleanup tools have many uses, they are primarily used to "clean up" slip-cast greenware by removing imperfections (seam lines and mold marks) and enhancing and sharpening cast-in details.

KK23 6"		\$4.15
KK24 6.5"		\$4.65
KB3 6.5"		\$4.65
KBB 8.5"		\$4.65
KA2 8.5"		\$5.35
KDPC 0.5"		\$4.49

DETAIL CARVING TOOLS

The curved blades of these tools are formed and precision ground to provide a very sharp cutting point that will easily carve miniature details such as facial features, hair, insignia, fingers, and jewelry on small ceramic figurines.

KDCL 5"		\$5.79
KDCS 5"		\$4.89
KK26 4.5"		\$4.35
KLFTS 5.5"		\$12.19 Set of 3

LACE TOOLS

Lace tools are designed to facilitate the application of slip-soaked lace to greenware boxes, figurines, etc. The curved, pointed blades are used for pressing lace in place and also cleanup and sgraffito work, as well as working in wax.





KAB 6.75"		\$3.93
KA3N 6.75"		\$3.65
KA3R 6.75"		\$3.65
KK21 6.5"		\$3.95
KK25 6.5"		\$4.29

CUT-OUT TOOLS

KCOR 4.5"		\$5.05
KCOH 5.7"		\$4.35

CLAY LIFT SETS

Makes the creation of new decoration patterns and varied effects possible. Difficult to obtain details such as feathers, plant details, petals, and scales are easily done with spoons contoured for easy insertion, lifting and removal from moist clay. 7"

KCLS-A		\$11.15
KCLS		\$11.15
		
		





SGRAFFITO TOOLS

KK27 6"		\$4.74
KWLS 6.25"		\$4.84
KBSS		\$3.39
KBSL		\$3.39
KDBSS		\$3.75
KDBS		\$3.69
KWS 6"		\$5.40

DRILL TOOLS

KDR2 5.5"		\$4.60
KDR4 4.75"		\$4.65
KDR6 4.5"		\$7.70
KSPD 6.75"		\$6.19

SAW TOOLS

KSBR 5-3/8"		\$4.99
KK31 5-3/8"		\$5.05
KK32 5-3/8"		\$5.35
KGBC 6"		\$6.89

TRIMMER KNIVES

KK34 5"		\$3.69
KUK 5.75"		\$8.79
KUKS		\$8.35
KSCP		\$2.25

CUT-OFF NEEDLES

KPCN 5.5"		\$1.34
KPRO 6.75"		\$3.20
KPNH 5"		\$2.30

XST14

Porcelain Needle Tool

\$5.95

XST15

Stoneware Needle Tool











RECESS SMOOTHER

KK20 6"		\$5.20
---------	--	--------

Tools

HOLE CUTTERS

Hole Cutters provide an easy method for cutting clean holes in wet thick-wall greenware and wheel-thrown items.

- KHCP1 3/16"  \$9.49
- KHCP2 1/4"  10.90
- KHCS1 3/32" sq.  \$6.05
- KHCS2 1/8" sq.  \$6.65
- KHCS3 3/16" sq.  \$7.65
- KHCS4 7/8" sq.  \$8.90
- KHC1 3/16"  \$4.79
- KHC1A 1/4"  \$4.99
- KHC2 5/16"  \$4.49
- KHC3 1/2"  \$5.55
- KHC4 7/8"  \$11.59

KMDT TEXTURING TOOLS



- KMDT  \$4.15
- KDG1 6.5"  \$5.69
- KWG2 6.5"  \$5.05
- KFTB 5.5"  \$3.85
- KSWB 5.5"  \$4.69

HANDLEMAKERS

- KHM1 4"  \$3.50
- KHM2 4"  \$3.54
- (For Mugs)

RIBBON TOOLS

These tools combine imported hardwood modeling ends with sharpened stainless steel ribbon cutting ends.
\$14.25 each

- KRE2 8-3/8"  \$14.25
- KRE3 9-3/4"  \$14.25
- KRE4 8-1/4"  \$14.25

8 INCH DOUBLE WIRE END TOOLS

This assortment of 8-inch tools provides the sculptor and potter with a series of shapes designed for medium duty cutting and slicing of clay. The wire ends are formed from high-strength, stainless steel and are firmly attached to hardwood handles with brass ferrules.

\$7.99 each

- K8A1 
- K8B2 
- K8C3 
- K8D4 
- K8E5 
- K8G7 
- K8H8 

WIRE TOOLS

Wire end tools are used to remove controlled amounts and shapes of clay. These 6-inch tools are suitable for light cutting and slicing. The ends are made from high-strength music wire and are firmly attached to the hardwood handles with brass ferrules.

\$5.35 each

- KD1 
- KD2 
- KD3 
- KD4 
- KD6 
- KD7 
- KD8 
- KD9 
- KD10 

FETTLING KNIVES

These knives are used to trim the pour hole waste and to remove mold marks from cast greenware.

- KF96  \$6.29 8" (Softer)
- KF97  8" (Harder)

6-INCH RIBBON TOOLS

These tools provide a variety of shapes for light cutting and slicing. The ends are formed from high-carbon, heat-treated steel and are firmly attached to the handles with brass ferrules. **\$5.25 each**



8-INCH RIBBON TOOLS

These tools are used by potters and sculptors for medium duty clay cutting, shaping, and slicing. The cutting ends are formed from high-strength sharpened stainless steel and are firmly attached to hardwood handles with brass ferrules. **\$6.55 each**

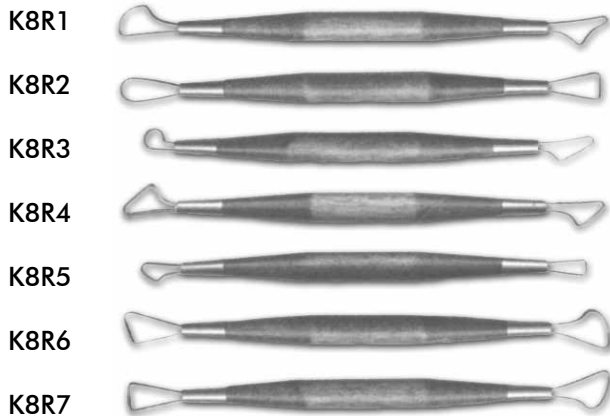

HEAVY DUTY SCULPTING TOOLS

Heavy duty tools designed to withstand the heavy side loads encountered when working on large sculpture and wheel thrown pieces. Made of stainless steel flat ribbon. **\$5.65 each**



KFW32 KFW31 KFW11 KFW12 KFW22 KFW21

5-INCH WIRE AND WOOD TOOLS

Wire and Wood Tools are combinations of wood modeling tools and wire tools. The 5-inch Wire and Wood Tools are used for delicate clay removal, modeling and shaping. They are made with plated high-strength .024" diameter music wire, brass ferrules, and imported hardwood.



6-INCH WIRE AND WOOD TOOLS

You will find the .035" diameter music wire great for light, as well as delicate clay removal and shaping.

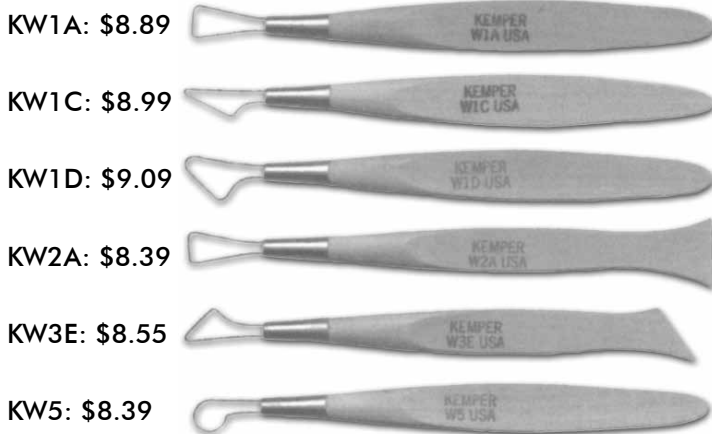

8-INCH WIRE AND WOOD TOOLS

Used for medium duty clay removal, modeling and shaping. The wire ends are .055" in diameter, and formed from high-strength stainless steel. Tips are firmly attached to 8" long hardwood handles with brass ferrules.



Tools

LOOP TOOLS, 5"

Loop Tools are used to remove controlled amounts of clay from wheel-thrown and sculpture pieces. The shaped cutting heads are made from heavy stainless steel ribbon with sharpened edges. Each tool, with its rugged hardwood handle, ensures a sure grip and easy manipulation in wet clay

KLT1 - 1/2"			
\$5.65			
KLT2 - 3/4"		KLT3 - 1"	\$5.55
\$5.55			
KLT4 - 1/2"		KLT5 - 1-3/4"	\$5.50
\$5.65			
KLT6 - 1-1/4"		KLT7 - 1-1/8"	\$5.55
\$5.55			
KLT8 - 1-3/4"			

IMPORTED WOOD MODELING TOOLS

6 inch imported wood modeling tools designed with the student in mind as well as the experienced sculptor. They offer a wide variety of shapes for cutting, slicing, smoothing, contouring, and pattern decorating in soft clay.

\$2.39 each

KJA4	
KJA5	
KJA6	
KJA8	
KJA15	
KJA17	
KJA18	
KJA22	
KJA24	
KJA28	
KJA32	
KJA37	

WOOD MODELING TOOLS

This series of wood tools offers a wide variety of shapes and contours for basic clay modeling. They are used for cutting, slicing, smoothing, contouring and pattern decorating in soft clay. They are made from imported hardwood and have a satin smooth finish.

KWT1 6"		\$5.89
KWT2 8"		\$6.35
KWT3 6"		\$6.29
KWT4 8"		\$6.35
KWT5 6"		\$6.19
KWT6 8"		\$6.35
KWT11 6"		\$5.89
KWT12 8"		\$6.29
KWT15 6"		\$6.29
KWT16 8"		\$6.19
KWT18 8"		\$6.35
KWT19 6"		\$6.29
KWT20 8"		\$6.29
KWT21 6"		\$6.19
KWT22 8"		\$6.29
KWT26 8"		\$6.29
KWT27 6"		\$6.29
KWT28 8"		\$6.35
KWT29 6"		\$6.19

PALETTE KNIVES

Palette Knives are used by artists and ceramic hobbyists for patching greenware, and grinding and mixing small quantities of china paints, oils, slips and glazes.

	KPAMini	\$6.49
	KP5D	\$7.49
	KP2	\$1.75



POTTERY TOOL KIT

Perfect for the beginning potter, in or out of the classroom. Used by schools and universities around the world, this kit is packaged in a reusable, clear vinyl bag with pockets to keep your tools together for travel or storage.

KPTK \$29.75

MINI RIBBON SCULPTING TOOLS

These miniature sculpting tools are made of fine ribbon steel heat treated for maximum strength. They are just the answer for your fine sculpting, detailing, and trimming requirements.

KMR1 - 6 \$4.95 each

KMRS \$25.49 set



KMR1 KMR2 KMR3 KMR4 KMR5 KMR6

TURNING TOOLS

Heavy steel head are brazed to steel shafts, plated and firmly set into smooth hardwood handle. Made to accurately shape clay or plaster on the wheel.

\$16.09 each



KTT1 Lg Teardrop 9-3/4"

KTT2 Sm Teardrop 9-3/4"

KTT3 Triangle 9-3/4"

KTT4 Right-hand Half moon 9-3/4"

KTT5 Left-hand Half Moon 9-3/4"

TRIM GIN TOOLS

Made of heat-treated tool-steel, hand sharpened for a superior cutting edge and covered with a rust-preventative coating.



C-15TG - 5-1/4" - Blue

C-19TG - 6-3/4" - Red

SS101 Round Rib

SS102 Long Rib

SS103 Soldner/Wombat Rib

SS302 Coleman/Mouse Rib

SB90 Voukos Brass Rib

BB Bali Bopper

\$21.99

\$7.75

\$7.75

\$23.95

\$7.75

\$23.95

\$50.00

THROWING STICKS

Patterned from the Japanese egote, these throwing sticks aid in shaping and compressing deep and narrow necked wheel thrown pieces. They are made in two sizes of fine imported hardwood polished to a satin smooth finish. 12-1/2"

KTS1 \$19.29

KTS2 \$18.09



SCULPTOR'S THUMB

This is a compact hand-fitting tool that duplicates thumb and finger strokes without abrasive wear on the sculptor's hands, fingers and thumbs. The Sculptor's Thumb is made from hardwood, 5" long and fits in most hands comfortably.

KSTH \$11.59



SPOUT MAKER

Made from solid maple. Makes spouts, feet, designs, appendages, and decorations. 8"

FAL2118 \$10.25



ULTIMATE SPOUT MAKER

Use to make long narrow and thin ceramic handmade spouts with length up to 15" long.

FAL3207 \$16.30



GARRITY MUSHROOM ANVILS

Crafted to fit in your hand with enough weight to easily shape a clay slab into a dish. Pair this tool with foam to press the anvil tops into slabs. 4 Sizes.

GM3 3 in. Mushroom Anvil \$26.00

GM4 4in. Mushroom Anvil \$32.00

GM5 5 in. Mushroom Anvil \$38.00

GM6 6 in. Mushroom Anvil \$44.00



Tools

Code	Description	Price
K210	Classique Sculpture Tool	\$16.89
K212	Classique Sculpture Tool	\$16.89
K402	10" Wood Model Tool	\$8.25
K404	10" Wood Model Tool	\$8.15
K406	10" Wood Model Tool Pkg	\$8.15
K8RSS	8 in. Ribbon Sculpting Set	29.15
KBAS	Basic Tool	\$2.499
KC3	Wooden Embossing Tool	\$3.95
KC4	Wooden Embossing Tool	\$3.95
KCBBH	Ceramic Bead Bar	\$11.29
KCUB	Clean Up Brush Dbl End	\$6.79
KDBSL	Double Ball Stylus, Large	\$4.39
KEMBS	Embossing Spoon	\$3.85
KHB1	Hake Brush	\$10.35
KDESS	Doll Eye Setter, Sm/lq	\$4.89
KDTA	Dipping Tongs	\$16.49
KELP	Element Pins (12 Per)	\$4.99
KELS	Element Staples (12 per)	\$5.99
KFT451	Fleshing Tool	\$6.99
KFT452	Fleshing Tool	\$6.99
KFT453	Fleshing Tool	\$6.99
KJA10	6 in. Wood Modeling Tool	\$2.39
KJA104	8 in. Wood Modeling Tool	\$2.39
KJA12	6 in. Wood Modeling Tool	\$2.39
KJA13	6 in. Wood Modeling Tool	\$2.39
KJA132	8 in. Wood Modeling Tool	\$2.39
KJA137	8 in. Wood Modeling Tool	\$2.39
KJA14	6 in. Wood Modeling Tool	\$2.39
KJA16	6 in. Wood Modeling Tool	\$2.39
KJA19	6 in. Wood Modeling Tool	\$2.39
KJA2	6 in. Wood Modeling Tool	\$2.39
KJA20	6 in. Wood Modeling Tool	\$2.39
KJA28	6 in. Wood Modeling Tool	\$2.39
KJA3	6 in. Wood Modeling Tool	\$2.39

Code	Description	Price
KJA7	6 in. Wood Modeling Tool	\$2.39
KJA9	6 in. Imported Wood Model	\$2.39
KJAS	6 in. Imported Modeling	\$19.59
KJPS	Primary Sculpting Tool	\$16.39
KK45	Kemper Klay Gun K45	\$23.49
KK45D	Replacement Disc For K45	\$6.15
KK45DS	Replacement Screen For K45	\$4.39
KKSP1	Special Ribbon Tool	\$8.39
KKSP4	Special Ribbon Tool	\$7.49
KPAS	Patching Spatula	\$5.69
KPL1	Pot Lifter, 6 Wide	\$15.25
KPL2	Pot Lifter, 5 Wide	\$14.75
KPL3	Pot Lifter, 4 Wide	\$14.49
KPT110	Square Trim Tool 3/4 in.	\$15.99
KPT135	Rounded Trim Tool 1/2 in.	\$14.75
KPT140	Spade Trim Tool 3/4 in.	\$15.99
KPT150	Blunt-Triangle Trim Tool 3/4	\$15.99
KPT410S	Pro-Line Trim Tool 3/4 in.	\$13.85
KPT480S	Pro-Line Trim Tool 3/8 in.	\$13.85
KPT510	Pro-Line Trim Tool 1 3/4 in. P	\$14.75
KPT511	Pro-Line Trim Tool 1 1/2 in. P	\$13.59
KPT570	Pro-Line Trim Birdbeak 2	\$14.75
KS10	Steel Scraper	\$3.99
KS11	Steel Scraper	\$4.99
KSBR	Saber Saw-Cuts Forward	\$5.59
KSBT	Spatter Brush	\$8.19
KSBTL	Spatter Brush Tool, Lq	\$11.99
KSSF	Spg Sndr, Fine, 320-400 Grit	\$3.40
KSSM	Spg Sndr, Med, 120-180 Grit	\$3.45
KSSMF	Spg	\$3.45
KSSSF	Spg Sndr, SuperFine, 500-6	\$4.49
KSSUF	Spg Sndr, Ultra Fine, 800-1	\$3.49
KUKR	Uk Blades	\$4.15

MUD CARVING BOWS

Designed to slice and cut pug and extrusions for hand building, or for use on the wheel. Made of plastic and stainless steel. Twisted or straight wire.

MUDCUTTERC	Curly	\$47.00
MUDCUTTERS	Straight	\$47.00
MUDCUTTERRC	Curly Replace	\$16.00
MUDCUTTERS	Straight Wire Only	\$10.00
MUDBOWC	\$47.00 Wire Only	\$16.00
MUDBOWS	\$47.00 Wire Only	\$10.00

ADJUSTABLE CLAY SLICER

Amaco adjustable clay cutter is easy to use, just grasp with both hands and slide into position, pull or push through clay..

ACS	\$19.50
ACSW	Replace.Wire \$6.60

KEMPER CLAY CUTTERS

3" hardwood handles firmly fastened to 18" of frame-quality stainless steel wire or hi quality nylon.

KK35	Steel	\$4.39
KK36	Nylon	\$4.99

KEMPER EX. LONG CURLY WIRE

4.5" toggle handles are firmly fastened to 34-1/2" of quality stainless steel twisted double wire.

KK37T	34 in.	\$5.09
KK38	36 in.	\$4.79



Wire Cutters

CUTTING WIRE

CCACW02	26"	\$2.99
---------	-----	--------

XIEM PRO-CUTTING WIRE TOOLS

Silicon grip handles, no tangle wires. Comes in 11", 13" & 19" lengths.

XPCW11	11 in.	\$5.95
XPCW13	13 in.	\$5.95
XPCW19	19 in.	\$5.95

MUD WIRE TOOLS

Silicon grip handles, no tangle wires. Comes in 9" & 15" in. lengths.

MUDWIRE	green/orng	\$9.00
MUDWIRE	red/pink/	\$9.00
MUDWIREB	Black	\$9.00

BEVEL CUTTER

Allows you to cut precision 45 and 60 degree angles into your slabs.

CCACW12	4"	\$12.00
---------	----	---------



Dolan Tools

Tools

All Dolan tools are handmade from high carbon knife steel and are designed with the production potter in mind.

300 series \$15.75

400 Series \$14.75

100 Series Large \$15.75
100 Series Small \$14.75



220-C \$26.95



"M" Series \$13.50

Clay Shapers

KEMPER WIPE OUT TOOL

Erase your mistakes quickly and accurately with this specialized rubber that attracts gold as well as most painting mediums. For use on non-porous surfaces.
KWOT \$8.99



CLAY SHAPER

Rubber tipped.
Set of 5.
CCADS07 \$12.00 SM

CCADS08 \$16.00 LG



Calipers

Calipers are used by potters and sculptors to transfer measurements from the model to the clay and to measure thickness and diameters. The hardwood caliper is made from imported hardwood. The aluminum calipers are made from a tough aluminum alloy, are lightweight and easy to handle, and will measure both inside and outside dimensions.

HARDWOOD CALIPER
KCA10 10" \$13.79

ALUMINUM CALIPERS
KAL8 8" \$10.39
KAL10 10" \$11.49
KAL12 12" \$13.89



LID MASTER CALIPERS

Take the guesswork out of sizing lids for your pots. One tool is all you need. Simply insert the narrow end of Lid Master into the pot and the wide end automatically becomes a sizing guide. Use it to create perfect fitting lids quickly and efficiently every time.
LID Standard \$14.95
LIDL Large \$29.95



Tools

WATER BUFFALO TOOLS

Made from genuine water buffalo horn, are perfect for sculpting moist clay work and burnishing clay surfaces when wet or leather hard.

CCAHY111 5" \$4.80

CCAHY113 5" \$4.80

CCAHY117 3" \$14.00

CCAHY117 3" \$9.60

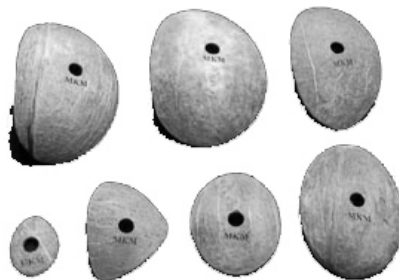

XIEM RETRACTABLE SCORING TOOL

The 6 sharp tines ensure depth and precision of scoring marks with little pressure but are efficiently retracted back into the plastic sheath for safety when not in use.

XRST \$6.75



COCORIBS

CocoRibs are made from real coconuts. The thickness and shape of the ribs are dependant on the age of the coconut. Seven in a set.

MKMCR \$18.95



WOODEN THROWING STICK

Used for shaping wheel thrown work on a wheel rotation of clockwise or counter-clockwise.

CCAWS125 stick \$12.00

WOODEN THROWING TOOLS

Wood Paddle
CCAWS121
13.5" \$12.00

Cutting Wire
CCACW02
26" \$2.40

Wood Point Head
CCAWS123
10" \$12.00

Wood Round Stick
CCAWS125
12.5" \$12.00

Wood Spoon Shape
CCAWS124
11" \$12.00

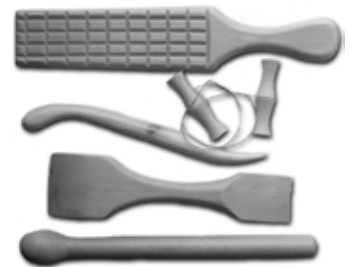

MUD BUMP TOOLS

These combing tools are used for creating surface decoration.

MUDBBUMP Baby Bump \$22.00
MUDBBUMP Straight Bump \$28.00
MUDBBUMP Curved Bump \$28.00



BAMBOO PADDLE
CCABM01 \$3.60



XIEM POTTER'S WAND II

Can be curved to reach into a narrow necked wheel-thrown form to shape pots like a professional. Left- or right-handed, made of silicone rubber over a stainless steel structure with a total length of 15.25" XXPW \$16.95

Slip Trailers & Decorators

PRECISION DECORATORS

Two clear bottles and four stainless steel tips allow you to draw intricate designs with underglaze, glaze, slip, and non-fired paints in four different widths. Can also be used to apply mender or wax resist.

PD \$7.99



XIEM SLIP TRAILING BOTTLES

Used to flow casting slips, glazes and engobes onto ceramic pieces

XCABS1 1oz. \$4.50
 XCABS2 2 oz. \$5.45
 XCABS44 oz. \$6.55
 XCABS8 8oz. \$7.65



XIEM CAP LOCKS

Close your slip trailers
 XCLA \$4.95



XIEM PRECISION TIPS

Replacement tips for slip trailers. Each pack contains 5 tips.

XPAT14G \$5.95
 XPAT15G \$5.95
 XPAT16G \$5.95
 XPAT17G \$5.95
 XPAT18G \$5.95
 XPAT19G \$5.95
 XPAT20G \$5.95
 XPAT21G \$5.95



FALCON 2 OZ. APPLICATOR

The perfect size for slip trailing on all sizes and types of potter
 FAL2804 \$5.95



XIEM COMPLETE APPLICATOR SET (36 PC)

This 36 piece set is a great tool for any type of liquid art media. Create very small intricate designs or large lines and shapes with various sized bottle tips. The tips can even be cut to seven sizes to fit your individual project needs.

XCABK \$21.95



KEMPER SLIP TRAILING BOTTLE

Used to flow casting slips, glazes and engobes onto ceramic pieces in raised decorative designs. With a 4-ounce capacity, this bottle is made from polyethylene making it squeezable, easy, and light to hold. Can be sealed with top.

KSTB 4 oz. \$4.49



XIEM PRECISION APPLICATOR SETS

Our system consists of a super-soft rubber applicator bulb, nickel-plated connector and your choice of 8 interchangeable tips. It's lightweight, easy to use and clean, plus our precision tip and connector system ensures that air pressure is regulated evenly and effortlessly.

XPAS1OZ 1 oz \$20.55
 XPAS3OZ 3 oz \$21.95

XIEM PRECISION APPLICATOR CONNECTOR
 XPACS \$15.75



Tools

Sure-Form

X-SHRED XIEM

The X-Shred can help you fine-tune forms to your exact specification. With an ergonomic handle, quick-release tempered steel blade and a compartment for shavings, it is the potters #1 choice for shaping and refining clay and plaster.

XSHRED **\$8.95**
XSHRED2B Replacement Blades **\$4.25**



MUD TOOLS SHREDDER

A small handy pot-sized sure-form rasp tool. **\$10.00 each**
Replacement pack: **\$7.50**



MUD TOOLS SHREDDER

Larger sure-form rasp tool.
MUDSHF Flat **\$12.50 each**
MUDSHC Conical **\$12.50 each**

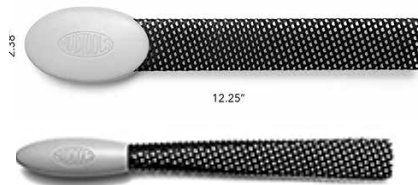

RUBBER STAMPS

Add uniform text and numbers to your ceramics project.

Code	Size	Letters	
CCASL101	1 1/16"		\$14.40
CCASL102	1/2"		\$13.20
CCASL103	3/8"		\$9.60
CCASL104	1/4"		\$7.20
CCASL105	3/16"		\$6.00
CCASL106	1/8"		\$4.80
CCASL10A	1 1/8"		\$22.80

Code	Size	Numbers	
CCASN101	1 1/16"		\$8.40
CCASN102	1/2"		\$7.20
CCASN103	3/8"		\$6.00
CCASN104	1/4"		\$4.80
CCASN105	3/16"		\$3.60
CCASN106	1/8"		\$3.00
CCASN10A	1 1/8"		\$12.00



SCOTT CREEK TILE CUTTERS

Sturdy metal cutters produce perfect tiles time after time. Sized for clay shrinkage.

4" **\$33.80**
6" **\$57.75**



ROSE CUTTER SET

The Rose Cutter Set consists of five round cutters and instructions for use. The cutters are used just like a cookie cutter on rolled-out clay to make round pads. These pads are then easily hand formed to resemble rose and other flower petals. Sizes range from 1/2" to 1-1/2" in diameter.

KK50 **\$13.35**



Pot Lifts

These lifts provide an easy method for removing pottery items from the throwing wheel without damaging the ware. They are made from rust free, high-strength aircraft aluminum.

KPL3 4" **\$14.49**
KPL2 5" **\$14.75**
KPL16" **\$15.25**

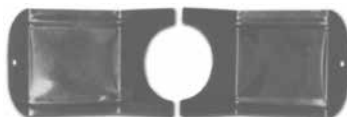

COMBING TOOLS

These combing tools are used for creating surface decoration.

SC163 Small **\$11.50**
SC162 Medium **\$11.99**
SC161 Large **\$13.50**



Kemper Pro-Line Tools

Kemper Pro-Line Tools are crafted from select hardwood handles. Comparable to Dolan tools, the steel loops and blades are made from "knife quality" high-carbon steel.

Code	Price
KPTM10	\$10.69
KPTM15	\$10.69
KPTM20	\$10.69
KPTM30	\$10.69
KPTM50	\$10.69
KPTM55	\$10.69
KPTM60	\$10.69
KPTM70	\$10.69
KPTM80	\$10.69
KPTM90	\$10.69
KPTM95	\$10.69



Code	Price
KPTS10	\$11.95
KPTS20	\$11.95
KPTS30	\$11.95
KPTS50	\$11.95
KPTS60	\$11.95
KPTS80	\$11.99
KPT512	\$11.99
KPT572	\$11.99



Code	Price
KPT410	\$13.85
KPT420	\$13.85
KPT430	\$13.85
KPT440	\$13.85
KPT445	\$13.85
KPT455	\$13.85
KPT460	\$13.85
KPT480L	\$13.85
KPT571	\$13.59
KPT572	\$12.09



Code	Price
KPT310	\$14.75
KPT315	\$14.75
KPT320	\$14.75
KPT325	\$14.75
KPT340	\$14.75
KPT345	\$14.75
KPT350	\$14.75
KPT360	\$14.75
KPT370	\$14.75

SCISSORS

Stainless and heavy duty. 17 cm.
CCACN68 \$4.99



ADJUSTABLE PARALLEL CUTTER

This adjustable parallel cutter tool has two blades (one fixed and one adjustable) to allow you to cut slabs with a uniform width. The perfect tool to cut slabs for use when handbuilding! 7" long plastic body with a built in ruler.

CCACP01 & 02
\$8.50



KEMPER WOODEN TEXTURE RIBS

Only \$9.39 or \$9.65 each

RBT 1 RBT 2 RBT 3 RBT 4

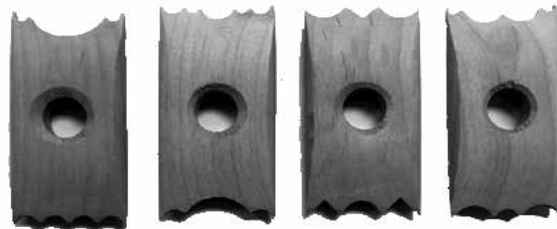

RBT 5 RBT 6 RBT 7 RBT 8

XIEM FLEXIBLE RULER

Take accurate measurements on curved surfaces, draw straight lines on slopes; the Xiem Flexible Ruler is adjustable for all of your shape-making and designing needs. Calibrations for inches and millimeters, perfect for any hand-building or wheel-throwing application where lines are hard to measure.

XFR16 \$10.95
XFR24 \$12.95



Ribs

XIEM SILICONE RIBS

Rigid Ribs 1-8
XPCR1-8 \$4.95 ea.

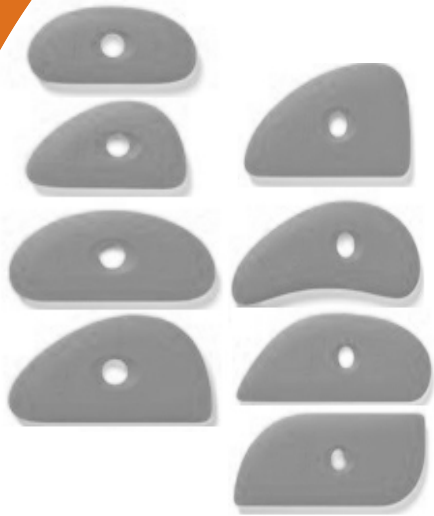

XIEM PLASTIC DECORATING RIBS

Plastic with different textures on 3 of 4 sides.
Set A,B or C: XUDRA, XUDRB, XUDRC \$13.95/ea.

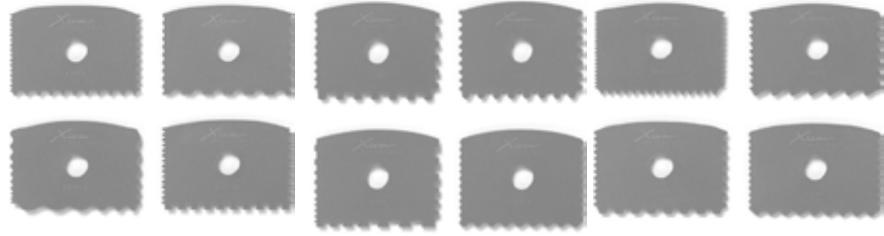

TRIM GIN RIBS

SS-103 Wombat Rib
Dye stamped from highgrade stainless steel.
6-7/8" \$21.90



SB-90 Voulkos Brass Rib
Made of half-hard spring-brass for demanding applications.
6-1/2" \$21.90



MKM RIBS

Wooden ribs in various shapes and sizes.
Each is finished with an oil and wax mixture that is deeply applied to make it more durable in water. However, please remove from water when not in use.

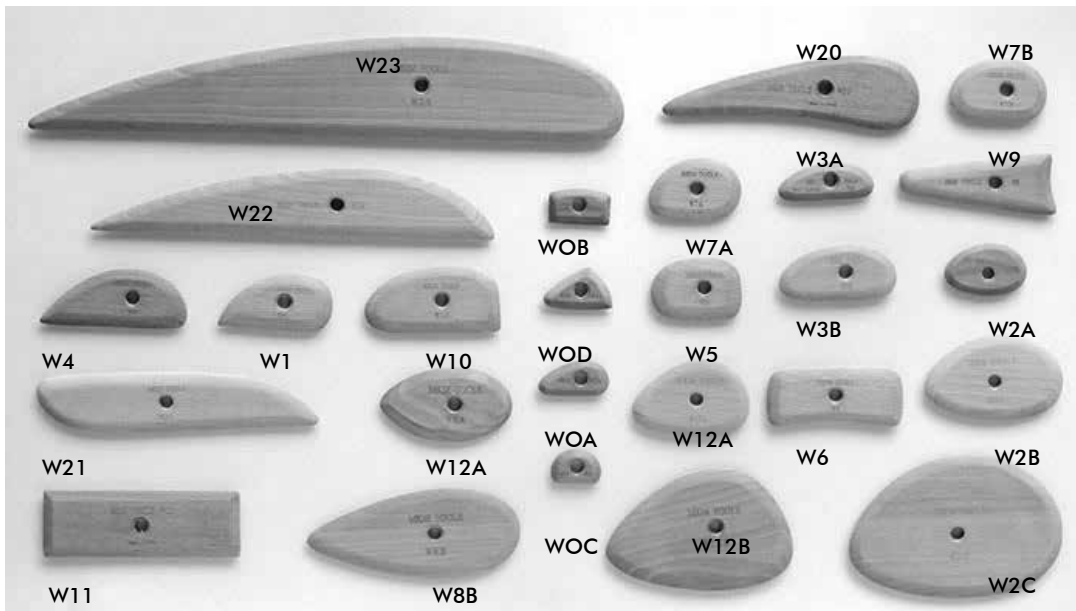

VAN GILDER PROFILED FOOT RIB

Produce an instant rounded foot profile by pushing this easy-to-use tool into the base edge of a wet pot on the wheel.
Size:
2" x 2-1/2" x 3/8" thick
\$6.25



WOa: 2.24"	\$3.00
W0c: 1.6"	\$3.00
W2B: 4.5" x 3"	\$4.95
W3A: .3" x 1.125"	\$3.95
W4: 4.625" x 1.875"	\$4.95
W6: 4.125" X 1.875"	\$4.95
W7B: 3.125" X 2"	\$4.95
W8B: 6.75" X 2.875"	\$8.95
W12A: 3.75" X 2.5"	\$4.95
W20: 8" X 2.125"	\$8.95
W22: 12.5" X 2.125"	\$12.95

W0b: 1.96"	\$3.00
W2A: 2.5" x 1.75"	\$3.95
W2C: 6.75" x 4.5"	\$8.95
W3B: 3.75" x 1.75"	\$4.95
W5: 2.75" x 2"	\$4.95
W7A: 2.875" X 1.875"	\$4.95
W8A 4.125" X 2.25"	\$4.95
W9: 5" X 2"	\$4.95
W12B: 6" X 3.875"	\$8.95
W21: 8.75" X 2"	\$8.95
W23: 18.5" X 3"	\$16.95

Ribs

MUD TOOLS: RIBS

Designed by potter Michael Sherrill, these ribs are made out of the "stainless steel of plastics" because of its wearing qualities. Unlike rubber, this material won't develop burrs. They burnish themselves over time. Different shapes and flexibilities provide for your working style.



Shape 0



Shape 1

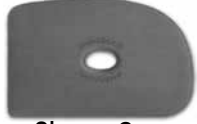

Shape 2



Shape 3



Shape 4



Shape 5

All five ribs come in each of the four styles and colors
MUD \$9.00

Very Soft - Red
 Use for compressing slabs, burnishing rims, and hand building.

Soft Flex - Yellow
 Use for smoothing, burnishing, porcelain, throwing, and hand building.

Medium Flex - Chartreuse
 Use for compressing bottoms, burnishing trim marks, throwing, and hand building.

Hard Flex - Blue
 Still flexible but stiffer, great for high burnish and large work.

KEMPER RUBBER RIBS

Designed for smoothing, shaping and finishing clay. Made from pliable rubber.

Black - Firm
KFRH 4-1/4" \$7.09
KFRSM 3-1/8" \$6.59

Blue -Soft
KFRSS 4-1/4" \$7.39
KFRSO 3-1/8" \$6.29



KEMPER SCRAPERS & METAL RIBS

Designed for smoothing, scraping, shaping and trimming clay. Made from flexible stainless steel.



KS1 4-5/8" \$3.40



KS3 4" \$3.55



KS4 3-7/8" 3.45



KS6 4" \$3.25



KSA10 3-3/4" 4.15



KS11S 6" \$4.89



KS12 6" \$4.99

KEMPER WOOD POTTER'S RIBS

Made from imported hardwood. Basic shapes for opening, shaping, curving, smoothing and trimming wet clay on the potter's wheel.



KRB1 \$7.99



KRB3 \$6.75



KRB5 \$9.69



KRB7 \$7.49



KRB2 \$7.09



KRB4 \$7.55



KRB6 \$8.59

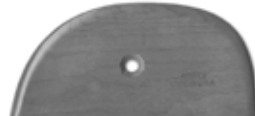

KRB8 \$8.79

MUD TOOLS METAL RIBS

Stainless Ribs are made of cutlery grade stainless steel with varying degrees of flexibility among the tool styles.



Shape 0 \$11



Shape 1 \$11



Shape 5 \$13



Shape 2 \$13

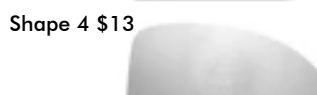

Shape 4 \$13

Long Scrapers \$17 to \$25



XL Long Scraper \$25



Hax Tool \$14



Special Styles include Pebble, Leaf, Bean, and Paisley. Textures and prices vary. From \$13 to \$16

Tools

Mallets and Paddles

MAPLE HAMMER

A heavy duty tool used for mashing dry or wet clay lumps, spreading out clay, decorating, and shaping large ceramic forms. Made from select hard maple. 4" x 2-7/8" head, 10" handle. **\$13.00**

CHINESE CLAY

A heavy duty hand pounding moist clay out flat. The slightly curved face allows the clay to spread out. Made from select hard maple. 5" x 2-7/8" head, 5" handle. CCAWM012 **\$48.00**



tool used in China for lumps to spreading it curved face allows the



SOLID WOOD MALLET

Use mallet to pound clay into slabs instead of using a rolling pin or slab roller. The clay becomes much more dense and strong. Sandalwood 13" 1.5 lbs **\$15.00**



WOOD PADDLE

This is a light weight but very strong paddle used for shaping clay. 12" X 4". **\$10.00**

KEMPER KLAY PADDLE

This imported wooden paddle measures 10.25" from end to end, a paddle width of 3.5" at the widest part of the paddle, with a 3" wide end. Use when throwing clay on the wheel. KPAD35 **\$10.49**



ROPE TEXTURE PADDLE

This paddle is used to create texture patterns, compress clay, remove air, and shape clay forms. Birch paddle wrapped with polypropylene rope. 12" x 2". **\$11.50**



Rollers

ROLLING PINS

Made from one piece of kiln dried solid maple, sanded & finished by hand, no plastic or metal parts to rust or wear out.

FAL107 30" \$47.00
FAL206 24" \$38.00
FAL306 18" \$31.00



PONY ROLLER

Two solid hardwood rollers, 4" x 1-5/8" and 2" x 1-5/8", held together with a heavy duty, welded-joint, chromed steel frame. Packed in a poly bag. FAL1005 **\$12.00**

FRENCH ROLLER

Hardwood french roller for smoothing rounded surfaces. 22-1/2" in length FAL503 **\$31.00**



Garrity Tools

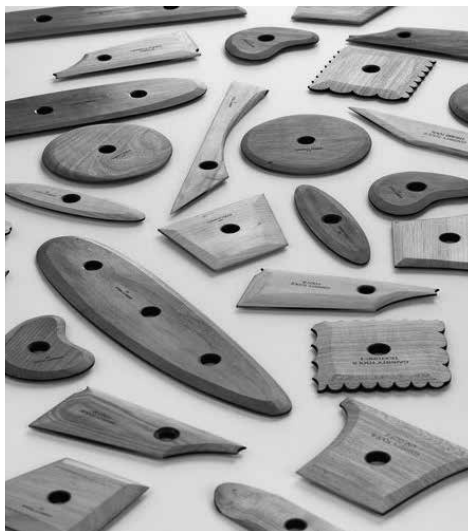

Code	Description	Price
GA4	A4	\$12.00
GB2	B2	\$12.00
GB3	B3	\$12.00
GC1	C1	\$12.00
GC3	C3	\$12.00
GC4	C4	\$14.00
GD3	D3	\$12.00
GF4	F4	\$20.00
GI1	I1	\$14.00
GI5	I5	\$12.00
GK1	K1	\$12.00
GN1	N1	\$14.00
GN3	N3	\$12.00
GO6	O6	\$12.00
GR1	R1	\$12.00
GS2	S2	\$12.00
GT5	T5	\$12.00
GT6	T6	\$16.00
GFishstick	Fishstick	12.00
GFishFillet	Fish Fillet	\$16.00

Code	Description	Price
GTEX1	Texture 1	\$16.00
GTEX2	Texture 2	\$16.00
GTEX3	Texture 3	\$16.00
GTEX4	Texture 4	\$16.00
GTEX5	Texture 5	\$16.00
GTEX6	Texture 6	\$16.00
GTEX7	Texture 7	\$16.00
GTEX8	Texture 8	\$16.00
GTEX9	Texture 9	\$16.00
GTEXM	Text. micro	\$16.00
GComb	Comb	\$12.00
GFoot2	Foot 2	\$14.00
GFoot4	Foot 4	\$14.00
GFoot 5	Foot 5	\$14.00
GFoot6	Foot 6	\$14.00
GFoot 8	Foot 8	\$14.00
GUnfoot 1	Unfoot 1	\$18.00
GUnfoot 2	Unfoot 2	\$18.00
GUnfoot3	Unfoot 3	\$18.00

MKM Paddles

TEXTURED PADDLES

Each textured paddle has a different pattern on each side and are great for altering the surface of pots, handles and coils.

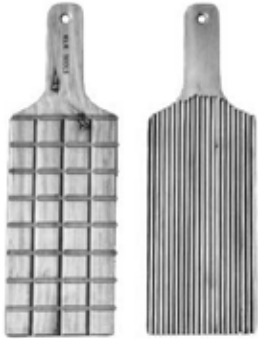

MKMLP4 \$18.95

LP5 \$18.95



SP1 \$11.95

SP2 \$11.95

MKM Decorating Disks

PATTERNED STAMPS

Various double sided wooden stamps in different sizes.
\$3.95-9.95



MKM DECORATING DISKS

Use these to create square, triangular, or other shaped forms, line up handles and spouts, or marking your piece for glaze or slip patterns. There are perforated holes along the radial lines of the disk which allow you to mark your pot without removing the disk.

- MKMDD04 4" Decorating Disk \$19.95
- MKMDD15 15" Decorating Disk \$34.95

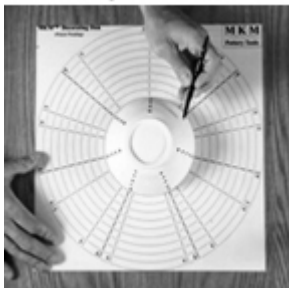
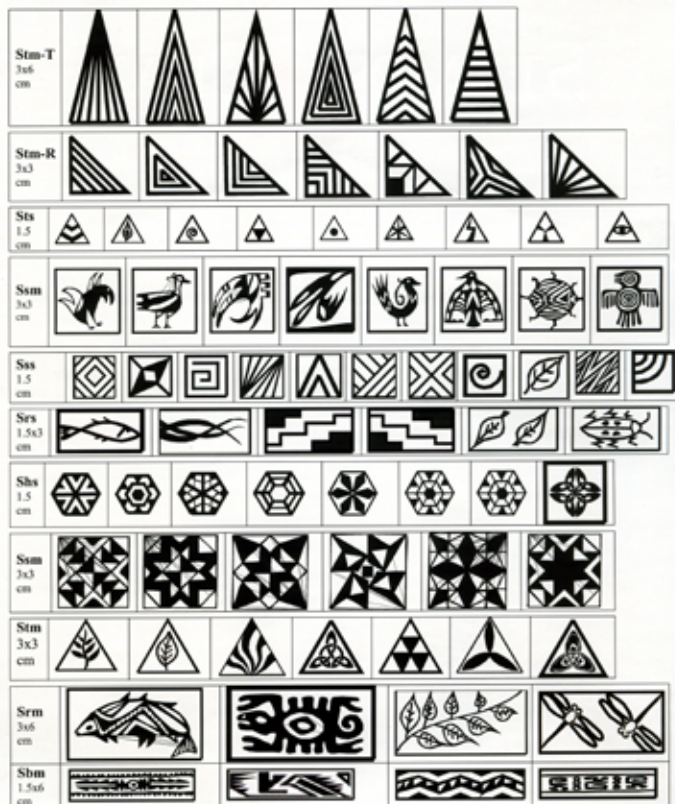

MKM Rollers

MKM TEXTURE ROLLERS

Hand Rollers with various patterns and in various sizes. Hardwood, excellent for slab building.

MKMLHR	Extra Large:	\$29.95
MKMBHR	Large:	\$19.95
MKMHR	Medium:	\$15.95
MKMTW	Twig Roller:	\$11.95



Wyatt

General Manager
Texture is a complex subject when it comes to working with clay.

It can be additive, through the use of slip-trailing techniques. And it can be subtractive, by removing material with a variety of tools. Then, there is stamping and rolling patterns, and MKM wooden tools are perfect addition to your toolbox for texture.

MKM ROLLERS WITH HANDLES

Hand Rollers with various patterns and in various sizes that fit onto wooden 2-part handles. Hardwood, excellent for slab building.

MKMRH1	Small Handle:	\$12.95
MKMRH2	Large Handle:	\$10.95
Rollers:		
MKMMRS	Roller Stamp Mini	\$7.95
MKMRM	Roller Stamp Medium	\$13.95
MKMRL	Roller Stamp Large	\$17.95
MKMFR	Finger Roller	\$11.95



Sponges & Scrubbers

Sponges

SILK SPONGE

SPSK2 Medium 2.5" \$1.99
 SPSK5 Large 4" - 5" \$4.99



ELEPHANT EAR SPONGE

SPES Small 1" - 2" \$1.03
 SPEM Medium 2" - 4" \$2.99
 SPEL Large 3" - 4" \$3.70
 SPELG Extra Large 4" - 5" \$6.50



SEA WOOL SPONGE

SPSW2 Medium 3" - 4" \$3.99
 SPSW5 Large 6" - 7" \$8.99



SYNTHETIC CLEAN-UP SPONGES

KSPR Small Round 2-3" \$1.10
 SPO Small Oval 4" x 5" x 1.75" \$1.99
 SPL Large Rectangular 4" x 6" x 2" \$4.99



XIEM SMOOTHING SPONGES

Medium, Smooth and Fine textures.
 Tapered Edges
 XPSFPC \$4.75



SPONGE HOLDER

Used to reach the bottom and inside walls of tall pieces. This sponge holder has a hardwood handle and special attaching screw to hold your favorite sponge. Sponge included.

KSPG 14" handle \$7.99
 KSPR Replacement sponge \$1.45



KEMPER SPONGETTE

These sponges come with two different length handles for convenience. The noninterchangeable sponge is made of soft cellulose material and used not only for cleaning, but decorating as well.

KK33 7" \$6.49
 KK33L 14" \$7.19

MUD SPONGE

Sponge shaped like the traditional kidney rib. Tough and consistent.

MUDSPW \$9.00
 MUDSPO, MUDSPB \$7.00



XIEM X-SPONGE SPONGES (REGULAR AND SLIM)

The Xiem X-Sponge has a chrome-plated brass rod that telescopes from 8-1/2" to 23". Sponge is approximately 1/2" x 2-1/2".

XS3SLIM X-Sponge Slim \$12.95
 XSPONGE2 X-Sponge \$12.95
 Refill Pack \$8.75



XS3RS

CHAMOIS STRIP
 1.5" x 4.5" strip.
 CHM \$1.25



Scrubbers and Scrapers

KEMPER RUBBER SCRUBBERS

Square 3" X 3" Sponge with sanding surface. Excellent for clean-UP on molds and dolls. Available with 100 or 220 grit surface.

KRS100 \$2.65
 KRS220 \$2.95

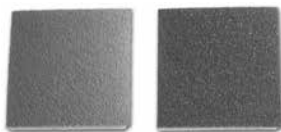

KEMPER GREENWARE FILES

Lightweight, these two-sided flexible files cut cleaning time even on low-fired porcelain bisque.

3/4" x 7" Coarse KGF2 \$5.89
 1/2" x 5" Coarse KGF3 \$5.65
 1/2" x 5" Fine KGFF-01 \$2.99

KEMPER GRIZZLY SANDING PADS

Use them on bisque, greenware, or wood. The even polish porcelain bisque. The two-sided pads are available in coarse or fine.

KGSF fine and KGSP coarse: \$5.99

KEMPER QUICK CLEANERS

Washable sheets that can be used over and over again. Available in different grits:

KKQC320: bisque and porcelain greenware
 KKQC400: porcelain bisque
 KKQC600: porcelain finishing and polishing
 (400 & 600) grits can also be used on fired underglazes, fired raised glaze surfaces, decal surfaces and china painted areas).
 \$3.95 or \$3.99/each

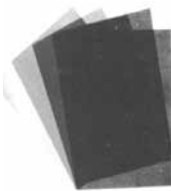

STAINLESS STEEL SCRAPER

Made from heavy duty stainless steel, providing for a very rust proof and long lasting tool. Use for scraping, texturing, refining, applying, chopping, moving, pressing, cutting, mixing, combing, pressing, and smoothing.

6" x 4-1/2"
 FAL275 \$11.00



Brushes

SMALL MOP BRUSHES

Made of goat hair.
CCAB1008 Brush Mop \$8.40
CCAB1086 S-6 Mop \$3.25
CCAB1089 S-9 Mop \$3.99



BRUSH SETS

CCAB652 Round set of 6 \$4.80
CCAB661A Flat set of 6 \$5.99
CCAB661A Fan set of 6 \$6.99

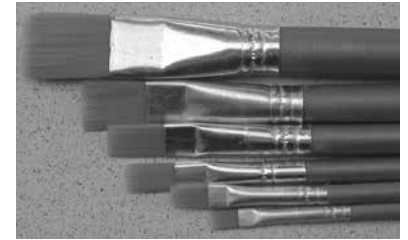

WOLF HAIR BRUSHES

Set of 3
CCAB020-2 \$3.60
CCAB040 Medium Brush \$9.99
CCAB0401 Large Brush \$4.99

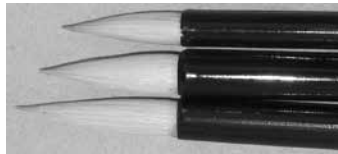

GOAT HAIR BRUSHES

Set of 3
CCAB020-1 \$3.60
CCAB050 Large \$6.99



MAYCO BRUSHES

CB200 Detail Brush \$7.50
CB425 1/2 in. Oval Brush \$7.50
CB434 3/4 in. Glaze Brush \$10.50
CB502 Small Fan Brush \$5.50
CB602 #2 Fan Brush \$6.15
CB618 Large Fan Brush \$10.50
CB624 #4 Fan Brush \$12.10



XIEM BRUSHES

XB05 3/4in. Glaze Brush \$4.95
XGB075 3/4in. Glaze Brush \$5.95
XGB1 1 in. Glaze Brush \$7.95
XGB2 2 in. Glaze Brush \$9.95



Brushes

YASUTOMO CALLIGRAPHY BRUSHES

These popular fine brushes are made with coarse, stiff horse hair which gives a crisp touch.



CC1	1/4" x 1-1/8"	\$5.65
CC2	5/16" x 1-1/4"	\$5.95
CC3	5/16" x 1-3/8"	\$6.35
CC4	3/8" x 1-15/16"	\$6.85
CC5	3/8" x 2"	\$7.30
CC6	1/16" x 2-1/8"	\$7.90



SW00	\$9.20
SW0	\$8.40
SW1	\$9.45
SW2	\$10.60
SW3	\$12.65
SW4	\$14.80
SW5	\$18.70
SW6	\$21.50

HAKE BRUSH

These brushes are of soft sheep hair and are made thick to provide a firm touch. They produce a wide variety of background effects. Can be snapped apart.

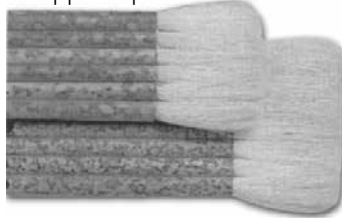

BH3	1" Wide	\$3.50
BH5	1-1/2" Wide	\$5.15
BH6	1-7/8" Wide	\$6.30
BH8	2-1/2" Wide	\$7.65
BH10	3-1/4" Wide	\$9.75
BH12	3-7/8" Wide	\$11.10
BH16	5-1/2" Wide	\$14.50

HAKE FLAT WASH BRUSHES

These sheep-hair brushes can be used with a wide range of media, including water color and oil, and are particularly well suited for ceramic art. A metal ferrule protects the brushes' roots. Inexpensive and long lasting.

BFC1	1" Wide	\$3.95
BFC2	1-3/8" Wide	\$4.45
BFC3	1-3/4" Wide	\$5.20
BFC4	2-1/2" Wide	\$6.75
BFC5	3-1/4" Wide	\$8.80
BFC6	3-7/8" Wide	\$9.85
BFC7	4-5/8" Wide	\$11.95

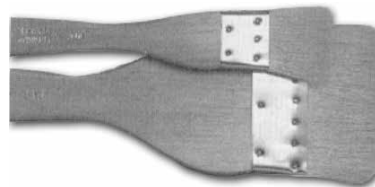

Sprayers & Scales

Sprayers

MOUTH GLAZE SPRAYERS

Low cost method of spraying glazes or oxides onto clay pieces quick, safe, and easy. Inside the metal container is a tiny tube from the bottom to the top. When you blow air through the top pipe, you create a venturi action that pulls the liquid up through the vertical tube and exits the sprayer as a fine mist. Made of galvanized iron sheet (MJ01, 03), or brass (MJ02).

MA100 2 oz. \$21.60

MA200 8 oz. \$22.80

MA300 16 oz. \$24.00



EZE SPRAY GUN

Sprayer is a siphon sprayer holding approximately 1 pint of liquid. Attach to your compressor, use 45 to 65 lbs. air pressure. Does not include hose or other brass hose fittings.

- Cast aluminum body
- Brass fittings
- Heavy-duty plastic cup
- Stainless steel pickup tube
- Quick Connect

\$29.95

Extra Jars: \$2.50



CENTRAL PNEUMATIC SPRAY GUN

Works great. Terrific value. Good Quality. Originally developed for spraying adhesive in the upholstery business, the EZE works great for ceramics. The air pressure required depends on viscosity (thickness) of the liquid being sprayed. Ranges from 25-45 psi for most ceramic materials.

\$39.95

\$2.75

Extra jars:



SPRAY BOTTLE

32 oz. professional high output sprayer. Wide mouth for easy fill. Adjustable nozzle. \$3.99



Scales

OZERI PRONTO DIGITAL MULTIFUNCTION KITCHEN SCALE

Accurate, easy-to-use digital scale - weighs up to 11.24lbs (with precise graduations of 0.05 oz.

Automatic Unit Button instantly converts between 5 units of measurements (g, lbs, lbs:oz, oz, ml) & displays results on an LCD screen. Precision Tare Button calculates net weight by automatically subtracting the weight of any container. Runs on 2 AAA batteries (trial batteries included, that powers off after 2-minutes to preserve battery life, and an easy-access battery compartment (no screwdriver needed).

Model	Price	Capacity
SCALEOZERI	\$19.99	13.22 lbs



MECHANICAL SCALE

Mechanical portion control scale features an extra large rotating dial with shatterproof lens and an internal stock mechanism that allows for faster, more accurate readings. For even easier readings,

the dial is angled back for convenient viewing. This mechanical scale has an 11 lb. capacity, and measures in 1 oz. increments.

6" x 5 1/4" food grade platform is removable for hassle-free cleaning so you can measure directly on the platform for added convenience. Constructed of corrosion-resistant stainless steel that is easy to clean and helps to maintain a sanitary work station.

Model	Price	Capacity
MSCALE	\$39.99	11 lbs

Studio Equipment

Safety Equipment

GVS ECLIPSE HALF MASK

Design offers maximum visibility, easy maintenance, and light weight. Mask fits the contours of the face, resulting in a form fitting mask that users will find very comfortable. Latex and silicone free, lightweight TPE face piece is comfortable to wear for long periods of time. Low profile filters provide unobstructed field of vision. Designed with a low breathing resistance to reduce the risk of user fatigue.

Filters allow easy breathing, resist moisture, and are designed in the mask for added comfort and less snagging points.



RSPLG/RSPMED
Silicon half mask **\$39.99**

RSP-CART Pair Filter Cartridges
\$19.99

DISPOSABLE DUST MASK

Moldex Disposable Respirators for dust and mists.
2300 With exhale valve



RSP-2300 \$3.60/each
RSP-2300-BOX \$34.00/Box of 10
RSP 2200 Regular \$3.60/each,
RSP-2200-BOX \$33.00/Box of 20

SAFETY GLASSES

TINTED - Protects against infrared and UV. Always wear protective glasses when looking through your peep into your kiln!

GLIR \$17.99



CLEAR - Protects against dust and particles only.
GLS \$4.99



CLAYPRON

Denim apron. Available with and without center zipper allowing you to split the apron skirt and protect your legs while wheel throwing.

Apron, Split leg
Size: 27"
CLAYPRON **\$39.99**



Gloves



NITRILE GLOVES

Disposable ambidextrous gloves. More durable than latex. Perfect for glazing.
M, L, XL.

GLOVE-NIT \$15.95/Box of 100
LAT \$0.30/each

WELDING GLOVES

Cowhide leather welders gloves fully lined with CushionCore lining for protection and comfort. Wide palm and thumb reinforcement guards. Kevlar stitched.

GL \$19.99



KEVLAR GLOVES & MITTENS

Great for raku. Won't melt, burn, or lose flexibility at temperatures as high as 800 degrees F. Non-asbestos. Fully sock-lined with wool.

KEV-GL \$65.95

Zetex Super High Temp Mittens
GHT \$152.75

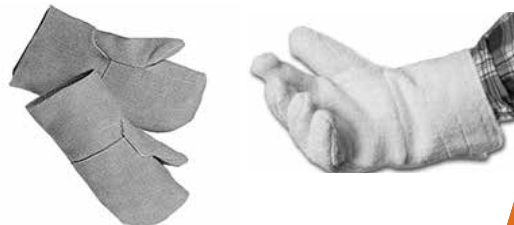

Studio Equipment

DURABLE PLASTIC STORAGE CONTAINERS

- 1 4oz jar with lid \$1.49
- 1 Pint jar with lid \$2.99
- 1 Quart jar with lid \$3.99
- 1 Gallon jar with lid \$5.99



ALOXITE STILT MARK STONES

These blocks are made of fine hard abrasive material. They are excellent for grinding glaze runs or rough spots on bisque ware.



- RUB 2" x 2.5" \$17.99
- RUBL 1" x 1" x 6" \$19.99

DIAMOND HAND PADS

Flexible foam pad with diamond abrasive on a flexible surface. 3.75" x 2.25" Use wet or dry, doesn't load up or wear out like sandpaper. Great for removing rough glaze edges, without damaging your piece.

- DHP60 60 Grit \$17.99
- DHP120 120 Grit \$17.99
- DHP200 200 Grit \$17.99
- DHP220 220 Grit \$17.99



HYDROMETER

These glass instruments measure the specific gravity of liquids, which is an important aspect of proper mixing of liquid glaze and slip. The hydrometer is placed in the container of liquid where it will float like a buoy and the meter can be read.

- 6" Reads from 40-60 baume \$24.95
- 11 1/2" Reads from 1.00 - 2.00 baume \$39.95

SCOOPS

Die cast aluminum, highly polished inside and out for easy cleaning. Size is overall length, including handle.



JIFFY MIXING WANDS

Stainless Steel Wand by Jiffy Mixer. Fits all 1/4" - 3/4" drills.

Model	Shaft Length	Container Size	Price
JMLM	10-1/4"	Pint	\$17.99
JMHS1	10-1/4"	1-2 Gallon	\$19.99
JMHS2	14-3/4"	1-2 Gallon	\$20.99
JMHS3	30"	1-2 Gallon	\$23.99
JMES	20-1/2"	2-5 Gallon	\$49.99
JMPS1	20-1/2"	5-10 Gallon	\$55.99
JMPS2	40"	10-50 Gallon	\$67.99
JMHD	40"	75-100 Gallon	269.95



GRADUATED CYLINDERS

- Two sizes for glazes and slips.
- TM 3028 100ml \$19.99
- TM 3029 250ml \$49.99



CLAYPEOPLE WAX RESIST

- Creamy white and water-soluble
- 4 oz. \$2.95
- Pint \$8.95
- Quart \$16.95
- Gallon \$54.95



Code Size Price

SCOOP05	5 oz	4.99
SCOOP12	12 oz	6.99
SCOOP24	24 oz	9.99
SCOOP38	28 oz	12.99
SCOOP58	58 oz	14.99
SCOOP85	85 oz	19.99

Studio Equipment

Gleco



GLECO TRAP

Economical and efficient way to prevent your sink from clogging with ceramic material. Easy to install and maintain. Connects below the sink and collects solids in a translucent bottle. Drain valve eliminates spillage by allowing all the water above the bottle to be drained prior to removal. Bottle exchange is rapid and done without the need of tools. Available in two sizes. Package includes trap, two bottles, and all of the installation hardware.
GLECO 64 oz. Package **\$140.00**

Sieves



TALISMAN ROTARY SIEVE

Has a manually operated crank handle, attached to a holder that houses three nylon brushes. As the handle is turned the brushes force the liquid or dry material through the screen.

The plastic body fits firmly on round containers. Comes equipped with one screen of your choice. Push-in stainless steel screens are interchangeable, from 40 to 200 mesh.

TM363

\$293.30

TALISMAN SIEVE REPLACEMENT SCREENS

Interchangeable for both the hand held and rotary sieve. Available in the following mesh sizes: 40, 60, 80, 120, 150, & 200

TM365

\$55.95



TALISMAN TEST SIEVE

Ideal for sieving stains and test batches. 4" wide at the top and 3" wide at the bottom. Available in mesh sizes of 40, 60, 80, 100, 120, 150, and 200.

TM368

\$33.30

LLC LAB SIEVES

These are inexpensive sieves with a high quality brass screen permanently molded into an unbreakable plastic pan. The screen is 6" in diameter, pan is 12" diameter. Fits conveniently on most 5 gallon buckets. Available in the following mesh sizes: 30, 40, 60, 80, 100, 120, 150, & 200.

TM312 through TM319 all **\$44.95/ea.**



Tongs

KEMPER DIPPING TONGS

Used to dip ware directly into glaze. Made of heavy plated steel & feature 4 sharp gripping points.

KDTA 10" **\$17.49**



KEMPER RAKU TONGS

These long handled tongs are made from rust-free plated steel.

Tubular handles are lightweight and strong. Jaws are solid and strong, yet gently grip all sizes of raku ware.

KRK37 41", 37 degree Jaw **\$65.99**

KRK45 31-1/2", 45 degree Jaw, Teeth **\$68.49**

LONG TONGS

\$75.95

These 52" tongs provide superior reaching capacity. Designed to maximize leverage to lift even the largest raku pieces. Heavy duty construction.



Tile & Adhesives

Bisque Tile

CERAMIC TILES

These white, low fire, bisqueware tiles are ideal for school projects as well as major decorative designs. They are available individually or by the box. Maximum firing range: cone 04



CODE	Dimensions	Each	Case	# Per Case
4x4	4" x 4" x .25"	2.99	219.99	80
6x6	6" x 6" x .25"	5.13	200.00	40

Ceramic Adhesives



MAGIC MENDER

For ceramic greenware or bisque. Add-on and fix broken greenware or bisque. For use up to cone 02. MMEND 4 oz. jar **\$15.88**

AZTEC HIGH FIRE MENDER

For porcelain, pottery, stoneware, etc. Repair, add-on and fix broken greenware or bisque. For use from cone 5 to cone 10. AZMEND 2 oz. **\$14.99**



APT II CERAMIC ENHANCER

Attach and mend greenware add-ons and broken bisqueware. Good for stress cracks on finished glazed pieces. In decorating it facilitates decal and slip application, bonding of air brushed colors and second glaze applications. (Detailed instruction brochure available with this product.)

APTC 2 oz. **\$6.50 (low fire)**

APTP 2oz. **\$7.50 (hi fire)**



AMACO BISQUE FIX

Attach or mend bisque. Fires to any temperature. 4 oz. jar **BFIX \$29.00**

CANE TEA POT HANDLES

Standard horseshoe. Holes facilitate attachment. Size is measured across the bottom.

4" **\$1.45**
5" **\$2.10**
6" **\$2.25**



BRAIDED CANE TEA POT HANDLES

Standard horseshoe. Braided bamboo sleeves over wire facilitate attachment. Size is measured across the bottom.

5" **\$5.00**
6" **\$9.60**

CORKS

Small and large end sizes noted below.

1" - 1.25" **\$.79**
1" - 1.5" **\$.99**
1.25" - 1.75" **\$1.59**
1.75" - 2" **\$1.99**
2" - 2.25" **\$2.29**



E6000

Non-epoxy glue, dries clear after 24 hours. Slightly flexible. \$6.

Low Fire Glazes

Amaco Teacher's Palette Glazes

Fires to cone 05.
Mixable gloss glazes, can be blended together to create an infinite color palette. TAP certified, lead free, dinnerware safe, brilliant color, and are safe for use by artists of any age. Try layering patterns and designs for a majolica-style decorative surface.

Code	Description	Pint	Code	Description	Pint
TP-1	Coal Black	19.00	TP-42	Granny Smith	19.00
TP-11	Cotton	19.00	TP-43	Green Leaf	19.00
TP-15	Gray	19.00	TP-51	Grape	19.00
TP-20	Sky Blue	19.00	TP-52	Raspberry	19.00
TP-21	Midnight Bl	19.00	TP-53	Pig Pink	19.00
TP-22	Blue Green	19.00	TP-54	Lilac	19.00
TP-24	Medium Blue	19.00	TP-56	Scarlett	19.00
TP-26	Robin's Egg	19.00	TP-58	Brick Red	19.00
TP-30	Caramel	19.00	TP-60	Lemon	19.00
TP-32	Fudge Brown	19.00	TP-62	Maize	19.00
TP-40	Mint Green	19.00	TP-64	Carrot	19.00
TP-41	Frog Green	19.00	TP-65	Pumpkin	19.00

Amaco Low Fire Gloss Glazes

Code	Description	Pint	Code	Description	Pint
LG-1	True Black	20.15	LG-45	Emerald Green	20.15
LG-2	Black Lustre	20.15	LG-46	Leaf Green	20.15
LG-10	Clear Transparent	18.00	LG-48	Chrome Green	20.15
LG-11	Opaque White	20.15	LG-50	Maroon	27.50
LG-14	Gray	20.15	LG-51	Lilac	27.50
LG-20	Medium Blue	20.15	LG-52	Petal Pink	20.15
LG-21	Dark Blue	27.50	LG-54	Mulberry Red	27.50
LG-23	Robin's Egg	20.15	LG-55	Purple	27.50
LG-24	Light Blue	20.15	LG-57	Intense Red	27.50
LG-25	Turquoise Green	20.15	LG-58	Brilliant Red	27.50
LG-26	Turquoise	20.15	LG-60	Dark Yellow	20.15
LG-27	Turquoise Crackle	20.15	LG-61	Canary Yellow	20.15
LG-30	Chocolate Brown	20.15	LG-62	Light Yellow	20.15
LG-32	Metallic Brown	20.15	LG-63	Brilliant Yellow	20.15
LG-34	Red Brown	27.50	LG-65	Amber	27.50
LG-36	Freckled Brown	27.50	LG-67	Fire Orange	27.50
LG-40	Dark Green	20.15	LG-68	Vivid Orange	27.50
LG-42	Light Green	20.15	LG-760	Pale Yellow	20.15
LG-44	Olive Green	20.15	LG-59	Hot Red	27.50

Fires to cone 05.
Always slow fire lead free glazes for best results. These glazes flow slightly during firing to a high gloss finish, correcting most application imperfections.

Amaco Texture Alligator Glazes

Fires to cone 05. Allows for many variations in texture which occur in firing. Apply to mature Cone 04 bisque, glaze fire to at slow speed.

Code	Description	Pint
LT-3	Old Pewter	\$30.00
LT-12	Speckled Green	\$22.00
LT-16	Green Stone	\$22.00
LT-22	Tahitian Blue	\$22.00
LT-48	Moss Agate	\$30.00
LT-132	Jewel Brown	\$22.00
LT-161	Tiger Eye	\$30.00
LT-166	Mottled Orange	\$30.00

Low Fire Glazes

Duncan (now Mayco) Glazes

Email for availability.
Fires to cone 06. Soft, muted sheen. Very little movement during firing, suitable for creative design work and controlled glazing techniques. Nontoxic, overglaze compatible and food safe.

Code	Description	4oz.	Pint	Gal.
SN 351	Clear Brushing	2.85	8.80	32.15
SN 351D	Clear Dipping			32.15
SN 352	White	5.90	16.30	

Leslie's Lava & Crackle

Fire to cone 06-05. Apply to bisque or raku. Applied thickly, it aggressively forms a cracked surface upon firing. Can be stained with oxides or glaze stains to achieve various colors.
Not food-safe.

Code	Description	Pint
500	Clear Crackle	\$12.00
502	Blue Crackle	\$13.00
600	White Lava	\$16.00
606	Black Lava	\$19.00

Amaco Opalescent Glazes

Code	Description	Pint
AO2	Black Tulip	\$22.00
AO10	Transparent Pearl	\$22.00
AO11	White Clover	\$22.00
AO12	Tawny	\$22.00
AO20	Bluebell	\$22.00
AO21	Aquamarine	\$22.00
AO23	Sapphire Blue	\$22.00
AO26	Turquoise	\$22.00
AO30	Autumn Leaf	\$22.00
AO42	Moss Green	\$22.00
AO52	Fuchsia	\$22.00
AO54	Dusty Rose	\$22.00
AO57	Mottled Burgundy	\$22.00

Fires to cone 06. Best over red clay or colored underglazes. High gloss finish when fired. Best results are achieved with three or four applications of glaze. On textured ware, the glaze flows thin on relief and thick in incised areas, giving an added dimension on the surface.

Amaco LG Low Fire Gloss

Glazes fire to a smooth, glossy finish at a witness Cone 05. Always slow fire lead free glazes for best results. AMACO® Gloss Glazes flow slightly during firing to a high gloss finish, while correcting most application imperfections. Great for enhancing texture!

Code	Description	Pint	Gallon
LG-1	True Black	\$22.00	100.00
LG-2	Black Lustre	\$22.00	77.00
LG-10	Clear Transparent	\$20.00	72.00
LG-11	Opaque White	\$22.00	85.00
LG-14	Gray	\$22.00	
LG-20	Medium Blue	\$22.00	
LG-21	Dark Blue	\$30.00	125.00
LG-23	Robin's Egg	\$22.00	
LG-24	Light Blue	\$22.00	
LG-25	Turquoise Green	\$22.00	
LG-26	Turquoise	\$22.00	
LG-27	Turquoise Crackle	\$22.00	
LG-30	Chocolate Brown	\$22.00	
LG-32	Metallic Brown	\$22.00	100.00
LG-34	Red Brown	\$30.00	
LG-36	Freckled Brown	\$30.00	
LG-40	Dark Green	\$22.00	
LG-42	Light Green	\$22.00	
LG-44	Olive Green	\$22.00	100.00
LG-45	Emerald Green	\$22.00	77.00
LG-46	Leaf Green	\$22.00	79.00
LG-48	Chrome Green	\$22.00	
LG-50	Maroon	\$30.00	
LG-51	Lilac	\$30.00	
LG-52	Petal Pink	\$22.00	113.00
LG-54	Mulberry Red	\$30.00	
LG-55	Purple	\$30.00	125.00
LG-57	Intense Red	\$30.00	
LG-58	Brilliant Red	\$30.00	125.00
LG-59	LG-59 Hot Red	\$30.00	
LG-60	Dark Yellow	\$22.00	
LG-61	Canary Yellow	\$22.00	100.00
LG-62	Light Yellow	\$22.00	
LG-63	Brilliant Yellow	\$22.00	
LG-65	Amber	\$30.00	125.00
LG-67	Fire Orange	\$30.00	
LG-68	Vivid Orange	\$30.00	
LG-760	Pale Yellow	\$22.00	

Low Fire Glazes

Leslie's N-Series Glaze

Fires to cone 06-05. Leslie's "N" series is a complete line of leadless low-fire glazes that have been used by schools, institutions, manufacturers, and fine artists for many years with exceptional results. Food-safe.

CODE	NAME	PINT
N-1	Clear Transparent	\$10.00
N-2	Periwinkle Blue	\$14.00
N-3	Transparent Brown	\$13.00
N-4	Deep Cobalt Blue	\$16.00
N-5	Leaf Grn Transparent	\$14.00
N-6	Phalo Green	\$15.00
N-7	Turquoise	\$13.00
N-8	Mahogany Brown	\$15.00
N-9	Slate Grey	\$14.00
N-10	Bottle Green	\$14.00
N-11	Deep Evergreen	\$16.00
N-12	Santé Fe Red Brown	\$15.00
N-13	Caramel	\$14.00
N-14	Tree Frog Green	\$16.00
N-30	White Semi Opaque	\$11.00
N-31	Lt Blue Semi Opaque	\$14.00
N-32	Opaque Brown	\$14.00
N-33	Bright Green	\$18.00
N-34	Deep Green Opaque	\$14.00
N-36	Pink	\$15.00

CODE	NAME	PINT
N-37	Maroon Red	\$18.00
N-38	Dark Blue	\$18.00
N-39	Yellow Opaque	\$16.00
N-40	Light Beige	\$14.00
N-41	Black	\$13.00
N-42	Pumpkin Orange	\$17.00
N-43	Deep Purple	\$18.00
N-44	Grey	\$13.00
N-45	Lavender	\$15.00
N-46	Deep Turquoise	\$14.00
N-47	Pine Green	\$16.00
N-48	Medium Blue	\$15.00
N-50	Red	\$24.00
N-51	Persimmon Red	\$18.00
N-52	Orange	\$18.00
N-53	Chartreuse	\$16.00
N-54	Canary Yellow	\$18.00
N-60	Valentine Red	\$17.00

Laguna Lead Free Low Fire

Fires to cone 06.

This series of glazes is recommended for schools and other users desiring Cone 06 glazes that do not contain lead. Safe for use on food and beverage containers when properly fired.

Code	Description	Pint
EM1002	Alabaster White	15.00
EM1004	Golden Aspen	15.00
EM1007	Black Patent	15.00
EM1009	Spring Green	15.00
EM1010	Elfin Green	15.00
EM1011	Frog's Pond Blue	15.00
EM1013	Fairy Blue	15.00
EM1014	Dutch Blue	15.00
EM1015	Fudge Brown	15.00
EM1019	Nude	15.00
EM1021	Sunburst	15.00
EM1022	Azure Green	15.00
EM1023	Danish Blue	15.00
EM1024	Maple Sugar	15.00
EM1027	Apple Green	15.00
EM1033	Kitchen Yellow	15.00
EM1050	Clear	15.00
EM1053	Clear Matte	15.00
EM1100	Eaashell	15.00
EM1101	Laguna Vanilla	15.00
EM1102	Taupe	15.00
EM1103	Peach Blush	15.00
EM1104	Creamy Peach	15.00
EM1105	Pink Blush	15.00
EM1106	Cloud Pink	15.00
EM1107	Sienna	15.00
EM1108	Maroon	15.00

EM1109	Violet	15.00
EM1111	Ginger Snap	15.00
EM1112	Honey	15.00
EM1113	Marigold	15.00
EM1115	Jade Green	15.00
EM1116	Blue Teal	15.00
EM1117	Wedgewood	15.00
EM1118	Silver Blue	15.00
EM1119	Turquoise	15.00
EM1130	Clear Lead Free	15.00
EM1131	Black Gloss	15.00
EM1132	Hunter Green	15.00
EM1133	Navy Blue	15.00
EM1134	Sage	15.00
EM1135	Charcoal	15.00
EM1136	Edgewater	15.00
EM1137	Cheddar Satin	15.00
EM1138	Cobalt Satin	15.00
EM1139	Maroon Satin	15.00
EM1140	Black Satin	15.00
EM1141	Teal Satin	15.00
EM1142	White Satin	15.00
EM1143	Marigold Satin	15.00
EM1145	Aqua	15.00
EM1146	Cool White	15.00
EM1147	Purple	15.00
EM1148	Silver Gray	15.00

Low Fire Laguna Glazes

Laguna Lead Free Low Fire, Continued

EM1149	Peacock	15.00	EM1242	Moss Green Sand	15.00
EM1150	Tile Blue	15.00	EM1243	Tea Dust	15.00
EM1151	Teal Blue	15.00	EM1244	Blue Brown Lava	15.00
EM1152	River Rock	15.00	EM1245	Light Cream	15.00
EM1153	Medium Gray	15.00	EM1246	Dark Ultramarine	15.00
EM1154	Morning Green	15.00	EM1247	Volcanic Ochre	15.00
EM1155	Sherwood	15.00	EM1248	Carnation	15.00
EM1156	French Lavender	15.00	EM1249	Mint Blue Lava	15.00
EM1157	Colorado	15.00	EM1260	Cat's Cream	15.00
EM1158	Sequoia	15.00	EM1261	Sea Foam	15.00
EM1159	Rootbeer	15.00	EM1262	Peach Fizz	15.00
EM1160	Derby Brown	15.00	EM1263	Peach Blossom	15.00
EM1161	Blue Gray	15.00	EM1264	Old Mauve	15.00
EM1162	Grape	15.00	EM1265	Coastal Fog	15.00
EM1163	Persian Blue	17.00	EM1266	Toasty Oatmeal	15.00
EM1165	Matador Red	17.00	EM1267	Gray Yellow	15.00
EM1166	Naranja	17.00	EM1268	Lava Smoke	15.00
EM1167	Rouge Satin	17.00	EM1269	Murky Lavender	15.00
EM1168	Carrot Satin	17.00	EM1270	Nocturnal Dust	15.00
EM1200	Sweet Dreams	19.00	EM1271	Blue Tiger Eye	15.00
EM1201	Mauve Ice	19.00	EM1272	Celadon Gray	15.00
EM1202	Root Beer Float	19.00	EM1273	Aztec Jade	15.00
EM1203	Raspberry Flow	19.00	EM1274	Blueberry Satin	15.00
EM1204	Carnation Cream	19.00	EM2100	Cobalt Black	20.00
EM1205	Peaches 'n Cream	19.00	EM2101	White	20.00
EM1206	Cool Blue	19.00	EM2102	Yellow	20.00
EM1207	Deep Lavender	19.00	EM2103	Light Blue	20.00
EM1208	Frosty Navy	19.00	EM2104	Cobalt Blue	20.00
EM1209	Obsidian Ice	19.00	EM2105	Dark Blue	20.00
EM1210	Frosty Gray	19.00	EM2106	Maroon	20.00
EM1211	Turquoise Ice	19.00	EM2107	Pink	20.00
EM1212	Wintergreen	19.00	EM2108	Buttercup	20.00
EM1213	Delta Cream	19.00	EM2109	Blue Green	20.00
EM1220	Butter Scotch	19.00	EM2110	Yellow-Green	20.00
EM1221	Desert Rust	19.00	EM2111	Dark Teal	20.00
EM1222	Pea Green	19.00	EM2112	Walnut Brown	20.00
EM1223	Lime Drops	19.00	EM2113	Valley Grape	20.00
EM1224	CalifDreaming	19.00	EM2114	Peach Glaze	20.00
EM1225	Pacific Swirl	19.00	EM2115	Old Gold	20.00
EM1226	Baltic Tundra	19.00	EM2116	Coral	20.00
EM1227	Cracklin' Rose	19.00	EM2118	Majolica Base	20.00
EM1228	Rain Forest Green	19.00	EM1165	Matador Red	17.00
EM1240	Hawaiian Crater	15.00			
EM1241	Twilight Crater	15.00			

Mid Fire Amaco Glazes

Amaco Potter's Choice

Fires to cone 5-6. Designed with the potter in mind! These glazes add fluid colors and effects to smooth or textured ware, with best results at Cone 5/6. See PC Layering charts to see more options.

Code	Description	Pint	Gallon
PC1	Saturation Metallic	34.00	131.00
PC2	Saturation Gold	20.00	89.00
PC4	Palladium	22.00	89.00
PC9	Vintage Gold	22.00	n/a
PC10	June Bug	34.00	n/a
PC11	Blue Spark	34.00	n/a
PC12	Blue Midnight	20.00	89.00
PC15	Satin Oribe	20.00	n/a
PC16	Purple Crystal	20.00	n/a
PC17	Honey Flux	20.00	n/a
PC20	Blue Rutile	20.00	89.00
PC21	Arctic Blue	20.00	89.00
PC22	Blue Stone	20.00	n/a
PC23	Indigo Float	20.00	89.00
PC24	Sapphire Float	22.00	89.00
PC25	Textured Turquoise	20.00	89.00
PC26	Blue Lagoon	20.00	n/a
PC27	Tourmaline	20.00	89.00
PC28	Frosted Turquoise	22.00	n/a
PC29	Deep Olive Speckle	22.00	89.00
PC30	Temmoku	20.00	89.00
PC31	Oatmeal	20.00	89.00
PC32	Albany Slip Brown	22.00	108.00
PC33	Iron Lustre	20.00	89.00
PC34	Light Sepia	20.00	89.00
PC35	Oil Spot	20.00	n/a
PC36	Ironstone	20.00	89.00
PC37	Smoked Sienna	20.00	n/a
PC38	Iron Yellow	20.00	89.00
PC39	Umber Float	20.00	n/a
PC40	True Celadon	20.00	89.00
PC41	Vert Lustre	20.00	89.00
PC42	Seaweed	20.00	89.00
PC43	Toasted Sage	20.00	89.00
PC44	Sage	20.00	n/a
PC45	Dark Green	20.00	89.00
PC46	Lustrous Jade	20.00	89.00
PC47	Emerald Falls	20.00	n/a
PC48	Art Deco Green	22.00	108.00
PC49	Frosted Melon	20.00	n/a
PC50	Shino	20.00	n/a
PC52	Deep Sienna Speckle	22.00	89.00
PC53	Ancient Jasper	20.00	89.00
PC55	Chun Plum	22.00	108.00
PC56	Ancient Copper	22.00	n/a
PC57	Smokey Merlot	22.00	108.00
PC58	Tuscany	20.00	n/a
PC59	Deep Firebrick	22.00	89.00
PC60	Salt Buff	20.00	n/a
PC61	Textured Amber	20.00	n/a
PC62	Textur. Amber Brown	20.00	n/a
PC63	Cosmic Tea Dust	20.00	89.00
PC64	Adventurine	20.00	89.00
PC65	Black Adventurine	22.00	n/a
PC66	Cosmic Oilspot	22.00	n/a
PC67	River Rock	20.00	89.00
PC70	Copper Red	22.00	n/a
PC71	Flambe	22.00	n/a

Amaco Celadon

Fires to cone 5-6. Like the beautiful ancient glazes they are modeled after, these glazes are glossy, transparent, and pool beautifully to add vivid accents to textured and carved surfaces. 100% mixable!



Code	Description	Pint	Gallon
C1	Obsidian Celadon	19.00	89.00
C3	Smoke Celadon	19.00	89.00
C5	Charcoal Celadon	19.00	n/a
C10	Snow Celadon	19.00	89.00
C19	Glacier Celadon	19.00	n/a
C20	Cobalt Celadon	19.00	89.00
C21	Sky Celadon	19.00	89.00
C22	Fog Celadon	19.00	n/a
C23	Ice Celadon	19.00	n/a
C25	Downpour Celadon	19.00	n/a
C27	Storm Celadon	19.00	89.00
C29	Deep Sea Celadon	19.00	n/a
C32	Ochre Celadon	19.00	n/a
C36	Iron Celadon	19.00	n/a
C40	Aqua Celadon	19.00	n/a
C41	Pear Celadon	19.00	n/a
C43	Wasabi Celadon	19.00	n/a
C47	Jade Celadon	19.00	n/a
C49	Rainforest Celadon	19.00	n/a
C50	Cherry Blossom Cel	19.00	n/a
C53	Weeping Plum	19.00	n/a
C54	Snapdragon Celad	19.00	n/a
C55	Poppy Celadon	19.00	n/a
C56	Lavender Celadon	19.00	n/a
C57	Mulberry Celadon	19.00	n/a
C60	Marigold Celadon	19.00	n/a
C65	Tangelo Celadon	19.00	n/a
C11	Mixing Clear	19.00	89.00

Amaco HF Series

Fires to cone 5-6. This glaze series combines favorites from the legacy Sahara and Celebration glaze lines. They produce interesting effects in oxidation and reduction and should be brush-applied to cone 04 bisque ware for the best results. Dinnerware safe.

Code	Description	Pint	Gallon
HF-1	Black	19.00	n/a
HF-9	Zinc-Free Clear	19.00	80.00
HF-10	Clear	19.00	80.00
HF-11	White	19.00	80.00
HF-12	Clear Satin	19.00	80.00
HF-26	Turquoise	19.00	n/a
HF-55	Coral Gloss	34.00	n/a
HF-56	Red Gloss	34.00	n/a
HF-125	Turquoise	21.00	n/a
HF-127	China Blue	31.00	n/a
HF-129	Baby Blue	21.00	n/a
HF-142	Chartreuse	31.00	n/a
HF-161	Bright Yellow	31.00	n/a
HF-165	Scarlet Red	34.00	n/a
HF-166	Orangerie	34.00	n/a
HF-167	Clementine	34.00	n/a
HF-170	Lilac	34.00	n/a
HF-171	Amethyst	34.00	n/a

Mid Fire Glazes

Leslie's Niji Glazes

Fire to cone 5-6 (Except LX1101 Clear)
The definition of Niji is "rainbow" in Japanese. These mid-fire glazes are color stable and very predictable. Can be intermixed to achieve various color shades. Complementary colors can be mixed to expand on the color palette. Lead Free - Dinnerware Safe

CODE	NAME	PINT
1079	Niji Storm Grey	\$12.00
1080	Niji Old Red	\$23.00
1081	Niji Black	\$14.00
1082	Niji Blue	\$13.00
1083	Niji Green	\$16.00
1084	Niji Orange	\$22.00
1085	Niji Purple	\$17.00
1086	Niji New Red	\$14.00
1087	Niji White	\$12.00
1088	Niji Yellow	\$13.00
1089	Niji Porky Pink	\$12.00
1090	Niji Paradise Purple	\$20.00
1091	Niji Twilight Blue	\$13.00
1092	Niji Morning Glory	\$15.00
1093	Niji Celadon	\$13.00
1094	Lime Twist Green	\$15.00
1100	Niji Clear Cone 5/6	\$8.00

Amaco Mid Fire Shino

Fires to cone 5. Influenced by the humble earthiness of tea ceremony bowls, Shino glazes give a traditional high-iron look to any high fire clay body. Beautiful on textured or smooth clay bodies, blendable to get the right degree of matte or glossy surface. Can also be layered with PC line of glazes for different effects. Food safe

Code	Description	Pint
SH11	Chai Gloss	19.00
SH12	Chai Matte	19.00
SH21	Acai Gloss	19.00
SH22	Acai Matte	19.00
SH31	Cacao Gloss	19.00
SH32	Cacao Matte	19.00
SH41	Oolong Gloss	19.00
SH42	Oolong Matte	19.00
SH45	Matcha Gloss	19.00
SH46	Matcha Matte	19.00
SH51	Hibiscus Gloss	19.00
SM52	Hibisc. Yellow	19.00

Amaco Mid Fire Satin Matte

Fires to cone 5-6. Satin Mattes break slightly over edges and texture and have a soft satin feel. Formulated to be 100% mixable (except for Orange & Red, which have a different base.) Use Clear Satin to lighten color tones, Satin Black to create shades, and Satin White to create tints. Food safe.

Code	Description	Pint
SM1	Satin Matte Black	19.00
SM10	Satin Matte Clear	19.00
SM11	Satin Matte White	19.00
SM20	Satin Matte Light Blue	19.00
SM21	Satin Matte Dark Blue	19.00
SM27	Satin Matte Teal	19.00
SM29	Satin Matte Blue Green	19.00
SM42	Satin Matte Mint	19.00
SM44	Satin Matte Chartreuse	19.00
SM51	Satin Matte Red	19.00
SM63	Satin Matte Yellow	19.00
SM68	Satin Matte Orange	19.00

Leslie's Koke & Kinu

Fires to cone 5-6. Koke (koh-kay) series was named to mirror the mossy surface on rocks found in Japanese gardens. They fire to a delicate mottled surfaces and work well on high relief. Kinu series satin matte glazes are a soft buttery non-reflective surface, which break nicely over a textured surface.

CODE	NAME	PINT
1102	Koke Blue	\$12.00
1103	Koke Yellow	\$12.00
1104	Koke Green	\$11.00
1105	Koke White	\$13.00
1106	Koke Black	\$13.00
1107	Koke Emerald	\$12.00
1108	Spanish Brown	\$11.00
1202	Acid Washed Blue	\$13.00
1203	Bue Green Algea	\$12.00
1204	Antique Celadon	\$11.00
1205	Antique Aquamarine	\$12.00
1206	Blue Smoke	\$11.00
1207	Sea Break	\$12.00
1208	Lunar Grey	\$11.00
1209	Desert Night	\$11.00
1210	Burnt Caramel	\$12.00
1211	Mustard Fog	\$11.00
1212	Lemon Crush	\$13.00
1213	Orange Ice	\$15.00
1214	Tangerine Dream	\$14.00
1215	Koke Blush	\$13.00
1216	Raspberry Ice	\$16.00
1110	Kinu White	\$13.00
1111	Kinu Slate Black	\$15.00
1112	Kinu Sierra Granite	\$13.00
1113	Kinu Serpentine Green	\$14.00
1114	Kinu Turquoise	\$14.00
1115	Kinu Red	\$20.00

Mid Fire Glazes

Laguna Dry Lake Glazes

Fires to cone 5. Inspired by the dry lake beds, this glaze works well with most clay bodies, & has been formulated to adhere without flaking. Apply to greenware or bisque. Brush on generously. Suited for sculptural work and decorative touches to the outside of functional pieces.

Code	Description	Pint
DL100	Fossil White	20.00
DL101	Teton Teal	20.00
DL102	Meta Blue	20.00
DL104	Glacier Ice	20.00
DL105	Black Ore	20.00
DL108	Lava Lakes	20.00
DL109	Hoodoo Orange	20.00
DL110	Sulfer Vent	20.00
DL111	Open Meadow	20.00



Laguna Crackle Glazes

Fires to cone 5. Select stock colors or blend your own stain or oxide to the base glaze, WC-130. Lead free & non toxic, but not dinnerware safe.

Code	Color	Pint
WC130	Fractal Cream	17.00
WC131	Tang Lime	17.00
WC132	Analin Green	17.00
WC133	Apache Green	17.00
WC134	Emerald Isle	17.00
WC135	Lacy Mauve	17.00
WC136	Catalina Crackle	17.00
WC137	Skye Crackle	17.00
WC138	Twilight Blue	17.00
WC139	Ocean Teal	17.00
WC140	Forest Jade	17.00
WC141	Desert Skye	17.00

Laguna Mystic Glazes

Fires to cone 5. These radical glazes redefine "break-up". Mottled colors create an exciting effect on functional or art ware. Select from stock colors, or blend your own choice of stain or oxide to the base glaze, WC-103.

Code	Color	Pint
WC100	Celadon Froth	15.00
WC101	Brilliant Sunburn	15.00
WC102	Pink Ice	15.00
WC103	Translucent Cream	15.00
WC104	Caramel Steam	15.00
WC105	Atlantis Aqua	15.00
WC106	Layered Fern	15.00
WC107	Antique Jade	15.00
WC108	Power Turquoise	15.00
WC109	Stormy Blue Gray	15.00
WC110	Turbulent Indigo	15.00
WC111	Spotted Blue	15.00
WC112	Chocolate Mesa	15.00
WC113	Mojave Dusk	15.00
WC114	Mint Irish Cream	15.00

Laguna Crystal Blossom

Fires to cone 5. These crystals are wonderfully three-dimensional. By using these glazes at the recommended firing schedule, you'll be amazed at the results! Select from stock colors, or blend your own choice of stain or oxide to the base glaze, WC-160. Lead free and certified nontoxic.

Code	Description	Pint
WC160	Lavender Filigree	18.00
WC161	Light Crystal Tea	18.00
WC162	Blue Snowflakes	18.00
WC163	Butter Drop	18.00
WC164	Mint Coffee	18.00
WC165	Translucent Mint	18.00
WC166	Crystal Forest	18.00
WC167	Plum Blossom Grn	18.00

Spectrum Floating Glazes

Fires to cone 5-6. Single glaze breaks into different color combinations.

CODE	NAME	PINT
S1431	Pearl White Floating	\$15.00
S1432	Curry Floating	\$15.00
S1433	Twilight Floating	\$15.00
S1434	Autumn Purple Floating	\$18.00
S1435	Sangria Floating	\$18.00
S1436	Kimchi Floating	\$18.00
S1437	Floating Celadon	\$15.00
S1438	Cactus Floating	\$15.00
S1439	Nori Green Floating	\$15.00
S1440	Floating Blue	\$15.00
S1441	Scandinavian Blue Floating	\$15.00
S1442	Clacier Floating Glaze	\$15.00

Leslie's Clears & Mattes

Code	Description	Pint
RSKT	Rusty Skillet	\$13.00
1100	Niji Clear Gloss	\$8.00
1150	Clear Satin Cone 5/6	\$10.00
1101	LX Clear Cone 5-10	\$8.00
M1	Gun Metal Matte	\$18.00
M2	Gun Metal Gloss	\$17.00
M3	Crystalline Green	\$15.00
N1	Clear	\$10.00
601	Kaleidoscope	\$10.00
SH46	Matcha Matte	17.00
SH51	Hibiscus Gloss	17.00
SM52	Hibisc. Yellow	17.00

Mid Fire Glazes

Georgie's Glazes

Code	Color	Pint
GGLW02	Blue Jeans	\$20.00
GGLW03	Avocado Ice	\$20.00
GGLW04	Peanut Ash	\$20.00
GGLW06	Liquid Luster Bronze	\$20.00
GGLW08	Copper Patina	\$26.00
GGLW10	Midnight Blue	\$26.00
GGLW12	Eggshell Wash	\$20.00
GGLW13	Sage Green	\$20.00
GGLW15	Jujube White	\$20.00
GGLW16	Faux Ash Teal	\$20.00
GGLW17	Turquoise Lagoon	\$26.00
GGLW19	Moss Thicket	\$20.00
GGLW21	Raw Honey	\$20.00
GGLW22	Rusty Nails	\$20.00
GGLW23	White Froth	\$29.00
GGLW25	Aqua Gemstone	\$20.00
GGLW26	Mustard Wood Ash	\$20.00
GGLW27	Emerald Wood Ash	\$20.00
GGLW28	Sapphire Wood Ash	\$20.00
GGLW30	Cinnamon	\$20.00
GGLW31	Dry Rust	\$20.00
GGLW32	Latte	\$26.00
GGLW34	Ohata Red	\$20.00
GGLW36	Nw Woods Green	\$20.00
GGLW37	Pure White Matte	\$20.00
GGLW39	Vanilla Cream Matte	\$20.00
GGLW40	Golden Raspberry	\$20.00
GGLW41	Cool Lime	\$20.00
GGLW42	Blueberry Matte	\$20.00
GGLW43	Bright Blue	\$20.00
GGLW45	Plum Black	\$20.00
GGLW46	Northern Lights	\$20.00
GGLW47	Kalamata Blk Matte	\$20.00
GGLW48	Cicada Crackle	\$26.00
GGLW49	Peking Blue Crackle	\$26.00
GGLW50	DragonsScale Crackle	\$26.00
GGLW51	Wu Blue Crackle	\$26.00
GGLW53	Yang Tze Crackle	\$26.00
GGLW54	Paprika Matte	\$29.00
GGLW55	Tumeric Matte	\$26.00

Code	Color	Pint
GGLW56	Chartreuse Matte	\$20.00
GGLW57	Dusty Blue	\$20.00
GPG601	Perfect White	\$26.00
GPG602	Incredible Black	\$20.00
GPG607	Nassau Blue	\$20.00
GPG608	Cobalt Blue	\$20.00
GPG611	Grape	\$20.00
GPG614	Grass Green	\$20.00
GPG615	Celedon Green	\$20.00
GPG616	Buckwheat	\$20.00
GPG617	Fiesta Yellow	\$20.00
GPG618	Terrazzo	\$20.00
GPG621	Wonder Red	\$26.00
GPG622	Flame Orange	\$26.00
GPG624	Ripe Apple Red	\$26.00
GPG626	Golden Yarrow	\$20.00
GPG628	Shiny Turquoise	\$20.00
GPG629	Super Clear	\$20.00
GPG630	Zinc Free Clear	\$20.00
GPG632	Blue Ink	\$20.00
GPG633	Pacific Blue	\$20.00
GPG634	Scotch Pine	\$20.00
GPG635	Black Patent	\$20.00
GPG636	Aegean Green	\$20.00
GPG637	Tutu Pink	\$20.00
GPG638	Blue Violet	\$20.00
GPG639	Hot Orchid	\$26.00
GPG640	Lavender Lupin	\$20.00
GPG641	White Cloud	\$20.00
GPG642	Blizzard Blue	\$20.00
GPG647	Burnt Orange	\$26.00
GPG648	Maroon	\$26.00
GPG649	Grey	\$20.00
GPG650	Brown	\$20.00
GPG651	Mottled Brown	\$20.00
GPG652	Chartreuse Gloss	\$20.00
GPG653	Golden Green	\$20.00
GPG654	No More Tears Clear	\$20.00
GS412	Black Satin	\$20.00

Fires to cone 5-6. These stoneware glazes were developed for use in schools and by artists who want high quality, color selection, glaze fit and value. They have a rich, creamy, touchable texture. Easy to use brushing, pouring or dipping. These colors also produce dramatic effects when combined with GLW Sculptural cone 5-6 glazes.

Coyote Enduro Glazes

Fires to cone 5-6. Engineered for durability. Resistant to crazing, staining, knife marking, scratching, dishwashing and leaching.

Code	Description	Pint
MBG180	Honeydew	13.40
MBG181	Cool Artichoke	11.70
MBG182	Satin Wht Liner	10.10
MBG183	Deep Avocado	10.90
MBG184	Cornsilk	11.50
MBG185	Walnut	10.70
MBG186	Gloss Wht Liner	10.40
MBG187	Apricot	12.80
MBG188	Sweet Plum	13.30
MBG189	Beechnut	11.00
MBG190	Summer Peach	12.00
MBG191	Blue Cornflower	12.50

Georgie's Interactive Pigments

Fires from cone 06 to cone 10! A blend of raw oxides designed to help create a lively, active surface. Concentrated form and intended to be mixed 50:50 with water for application.

Code	Description	Pint
GIP202	Tree Bark 4oz.	\$10.00
GIP203	Golden Straw 4oz.	\$11.00
GIP205	Autumn Foliage 4oz.	\$10.00
GIP206	Sand & Surf 4oz.	\$10.00
GIP207	Steel Black 4oz.	\$11.00
GIP208	Winter Storm 4oz.	\$11.00
GIP211	Worm Wood 4oz.	\$10.00
GIP212	Indigo 4oz.	\$11.00

Mid Fire Coyote Glazes

Archie's Glazes

MBG026	Gun Metal Grn	27.00
MBG028	Blue Purple	27.20
MBG031	Red Gold	26.30
MBG034	Archie's Base	26.20
MBG055	Opal	22.00
MBG056	Eggplant	27.20
MBG057	Rhubarb	29.30
MBG058	Ice Blue	27.20
MBG240	Frosted Topaz	29.80
MBG241	Magenta Sky	28.40
MBG242	Papaya	30.60
MBG243	Parakeet Yellow	29.00

The Archie's Series can be challenging to use, but rewards your skill with some of the most beautiful glazes available. They flow and interact with other colors dramatically, creating fantastic finishes unlike anything else possible in an electric kiln. They are also strongly affected by slow-cooling.

Satin Glazes

MBG074	Alabaster Satin	10.50
MBG075	Baby Blue Satin	11.90
MBG076	Cerulean Satin	11.50
MBG077	Charcoal Satin	11.70
MBG078	Cherry Satin	19.30
MBG079	Coral Satin	15.70
MBG080	Forest Satin	11.40
MBG081	Hazelnut Satin	11.10
MBG082	Lapis Satin	12.90
MBG083	Lemon Crm Satin	16.10
MBG084	Orchid Satin	17.20
MBG085	Seafoam Satin	13.00

Satin glazes have a soft, opaque surface that feels smooth to the touch. Durable, bright, and reliable, they are the perfect series for any functional potter seeking a contrast from more typical gloss glazes. They are not runny, are easy to use, and look great with the Archie's series.

Gloss Glazes

Coyote Gloss Glazes provide bold, bright, solid colors for your ware. Durable and not runny, these glazes are equally suited to both decorative and practical ware. They combine great with other Coyote glazes, especially the Archie's

Frank's Celadon Glazes

Frank's Colored Celadons are a beautiful series of translucent glazes. Because they can be seen through, they are perfect for work with fine details or carving, or as an alternative to clear for ware with underglaze. They do not run and look great on their own or combined with other glazes.

MBG098	Dusty Rose	14.90
MBG099	Sedona Sunset	14.70
MBG100	Peach Blush	13.50
MBG101	Stormy Sea	10.30
MBG102	Aqua	12.80
MBG103	Key Lime	11.20
MBG104	Peacock Green	11.00
MBG105	Root Beer	10.20
MBG106	Sunshine Yellow	13.80
MBG107	Night Sky	10.50
MBG108	Sapphire	10.50
MBG109	Rainy Day	12.00

MBG001	Almost Teal	11.90
MBG002	Black	12.10
MBG005	Chrome Green	11.90
MBG006	Cinnamon Stick	11.80
MBG007	Clear	10.50
MBG008	Cobalt Blue	13.00
MBG011	Eggshell	10.70
MBG013	Light Blue	11.90
MBG015	Mint	13.50
MBG017	Red Orange	17.00
MBG019	Red	21.20
MBG020	Orange	15.90
MBG023	White	11.30
MBG025	Yellow Orange	13.30
MBG048	Oatmeal	11.00
MBG050	Buttercup	18.80
MBG051	Pumpkin	16.70
MBG053	Pansy Purple	16.80
MBG054	Violet	23.50
MBG071	Really Red	20.40

Mid Fire Coyote Glazes

Copper & Iron Glazes

Code	Color	Pint
MBG027	Toshi Brown	11.10
MBG032	Rust Brown	15.10
MBG035	Copper Blue	12.10
MBG036	Crazed Copper	12.80
MBG037	Oasis	12.20
MBG040	Saturated Iron	10.70
MBG120	Bronze Temmoku	28.00
MBG130	Snowy Plum	16.50
MBG131	Oxblood	17.40

One of our most varied series, the Copper and Iron Glazes provide beautiful, traditional looks for ceramic wares. They each have their own properties, but most are durable enough for functional ware.

Texas Two-Step Oilspot

MBG140	Licorice	14.90
MBG141	Coffee Bean	11.50
MBG142	Brick Red	29.00
MBG150	Blue Moon	14.80
MBG151	Birch	13.60
MBG152	Texas Rose	22.20
MBG153	Marshmallow	13.50
MBG154	Sea Mist	14.30

The Texas Two-Step Oilspots are a specialized series that use pairs of glazes to create unique effects. Anywhere that one of the five overcoats is laid on top of Licorice, Coffee Bean, or Brick Red, a stunning spotted pattern will appear during firing. Thicker applications lead to bigger spots. Try using wax resist after the first layer to create negative space designs.

Constellation Glazes

The Constellations are the first line of glazes designed to shine in both regular and slow-cooled firings. Thickness, firing temperature,

MBG170	Autumn Spice	24.40
MBG171	Mars Red Iron	12.00
MBG172	Light Gold	25.70
MBG173	Summer Spice	20.80
MBG174	Orion	24.80
MBG175	Antares	30.70
MBG176	Andromeda	25.30
MBG177	Aquila	24.60
MBG178	Gemini	24.20
MBG179	Aries	27.00

Mottled Glazes

The Mottled Series are designed to produce beautiful variegated colors with ease. Simple to apply and suitable for all types of ware, these colors are stunning on their own or combined with other glazes. They may appear thick in the jar and should be applied thick.

MBG004	Cactus Green	12.50
MBG009	Croc Blue	12.70
MBG012	Fire Opal	17.30
MBG016	Mottled Blue	13.60
MBG021	Sunset Pink	14.20
MBG038	Pam's Green	12.80
MBG066	Jb Brown	12.10
MBG070	Pam's Blue	14.20

Enduro-Color Glazes

MBG180	Honeydew	13.40
MBG181	Cool Artichoke	11.70
MBG182	Satin White Liner	10.10
MBG183	Deep Avocado	10.90
MBG184	Cornsilk	11.50
MBG185	Walnut	10.70
MBG186	Gloss White Liner	10.40
MBG187	Apricot	12.80
MBG188	Sweet Plum	13.30
MBG189	Beechnut	11.00
MBG190	Summer Peach	12.00
MBG191	Blue Cornflower	12.50

Enduro-Color Glazes.

Engineered for durability. Resistant to crazing, staining, knife marking, scratching, dishwashing and leaching.

- For the illusion of depth
- Excellent on texture
- For both Red and White Clay

Mid Fire Coyote Glazes

Fantasy Glazes

Fantasy Glazes can vary dramatically in appearance depending on the clay body used, the thickness of application, and in some cases, the firing. They can be runny, so it's important to test carefully.

MBG210	Ancient Iron	19.60
MBG211	Azure Dream	24.60
MBG212	Enchanted Sunset	23.10
MBG213	Fairy Rose	25.00
MBG214	Sorcerer's Stone	22.40
MBG215	Unicorn Horn	20.30
MBG216	Amethyst	24.80
MBG217	Antique Pearl	20.70
MBG218	Dragon's Eye	23.10
MBG219	Firefly Garden	22.80
MBG220	Hydra Scale	21.60
MBG221	Phoenix Egg	22.00

Shino Glazes

Our Shino glazes are gorgeous and most unusual, a rare combination of beauty and reliability. The color is sensitive to thickness, breaking brown where thinner and giving interest to the surface. Very user friendly, the Shinos are easy to apply, are not runny and are at their best over texture; they're also great over other glazes.

MBG042	Shino	25.80
MBG043	Blue Shino	27.60
MBG044	Green Shino	25.50
MBG045	Light Shino	24.40
MBG067	Light Blue Shino	24.80
MBG068	Light Grn Shino	24.70
MBG086	Butterscotch Shino	28.10
MBG087	Cedar Shino	33.00
MBG088	Gldnrod Shino	26.60
MBG089	Leopard Shino	24.90
MBG090	Mocha Shino	26.40
MBG092	Plum Shino	29.60
MBG093	Pistachio Shino	27.20
MBG094	Sandstn Shino	26.60
MBG096	Steel Gray Shino	26.10
MBG097	Sunrise Shino	30.10

Vibro-Color Glazes

MBG200	Mediterranean Sea	14.30
MBG201	Passion Red	16.60
MBG202	Periwinkle	11.80
MBG203	Sundrop	13.40
MBG204	Tiger Lily	15.00
MBG205	Turquoise Lake	12.10

Crystalline Slow-Cool Glazes

Crystalline Slow Cool Glazes are a great way to add exciting new details to your work. They are less runny than traditional crystal glazes, removing the need for a drip tray, and can be fired with other, non-crystal glazes. They do still run, so take care with your application!

MBG160	Ivory Crystal	16.00
MBG161	Crystal Celadon	16.10
MBG162	Crystal Lagoon	20.90
MBG163	Crystal Aurora	17.00
MBG164	Crystal Nebula	16.00
MBG165	Rose Crystal	16.00

Matt and Crawl Glazes

Coyote Matt glazes are a favorite series for sculptors everywhere. They provide a strong color tone and nice variety without a glossy finish. They are very stable and reliable, almost never running or behaving unexpectedly.

MBG024	Blue Matt	13.40
MBG029	Creamy Matt	12.10
MBG030	Creamy W/Specks	12.40
MBG033	Turquoise Matt	12.10
MBG047	Green Matt	12.70
MBG049	Iron Matt	12.10
MBG062	Blue Crawl	17.40
MBG063	Cactus Crawl	16.60
MBG064	Chocolate Crawl	16.40
MBG065	Croc Crawl	16.80
MBG073	White Crawl	15.90
MBG110	Black Crawl	18.00

Vibro-Colors are as stable and reliable as Enduro-Color Liner Glazes, but loaded up with colorant for a vibrant pop. They do not run, resist scratching and crazing, and look pretty much the same in all firing cycles.

Mid Fire Laguna Glazes

Laguna Moroccan Sand Glazes

Fires to cone 5-6. A broad selection of gloss, mottled and matte finishes in warm stoneware colors. may be fired in oxidation or reduction. Lead free and safe for use on food and beverage containers when properly fired. Gallon sizes and dry glazes available by special order.

Code	Color	Price	Code	Color	Price
MS3	Wheat	15.00	MS74	Spring Green	15.00
MS4	Forest Green	15.00	MS75	Chive	15.00
MS5	Speckled Blue/Grey	15.00	MS76	Sea Foam	15.00
MS6	Gloss Black	15.00	MS77	Jade	15.00
MS9	Sandy Matte	15.00	MS78	Forest Green	15.00
MS10	Tobacco	15.00	MS79	Alfred Blue	15.00
MS12	Redwood Matte	15.00	MS80	Dutch Blue	15.00
MS13	Lemon Yellow	15.00	MS81	Wedgewood Blue	15.00
MS15	Ochre	15.00	MS82	Sky Blue	15.00
MS17	Golden Green	15.00	MS83	Maroon	15.00
MS18	Robin's Egg	15.00	MS84	Sunflower	15.00
MS19	Cream	15.00	MS85	Peach Blush Dry	15.00
MS20	Royal Blue	15.00	MS86	Peanut Butter Dry	15.00
MS22	Green Tweed	15.00	MS89	Dark Gray Dry	15.00
MS23	Dark Turquoise	15.00	MS90	Blackberry Wine	15.00
MS26	Snow Flake	15.00	MS91	Carnation Pink	15.00
MS27	Peacock	15.00	MS93	Peach	15.00
MS29	Clear Bright	15.00	MS94	Black	15.00
MS32	Chun Red	15.00	MS95	Peacock	15.00
MS33	Bamboo Ash Matt	15.00	MS96	Dynasty Red	20.00
MS34	Burnt Sienna	15.00	MS97	Mandarin Orange	20.00
MS35	Sage Matte	15.00	MS98	Red Satin	20.00
MS36	Blue Frost Matte	15.00	MS99	Orange Satin	20.00
MS37	Turkish Amber	15.00	MS100	Infinte Clear	15.00
MS38	Fern Mist	15.00	MS220	Nebula Blue Base	17.00
MS39	Desert Yellow	15.00	MS221	Desert Blue	17.00
MS41	Batik Blue	15.00	MS222	Sang De Boeuf	17.00
MS42	Speckled Moss	15.00	MS223	Desert Sunset	17.00
MS43	Amethyst Matte	15.00	MS224	Mint Spice	17.00
MS44	Mottled Spice	15.00	MS225	Smokey Gray	17.00
MS46	Agate	15.00	MS226	Fiesta Lime	17.00
MS47	Castile Blue	15.00	MS227	Lime Burst	17.00
MS48	Rafia	15.00	MS228	Sea Gold	17.00
MS49	Oasis Blue	15.00	MS229	Sea Grass	17.00
MS50	Dutch Sprinkle	15.00	MS230	Desert Sand	17.00
MS51	Pippin Green	15.00	MS231	Brown Slate	17.00
MS52	Cerulean	15.00	MS250	White Pebble Base	17.00
MS54	Emeraude	15.00	MS251	Yellow Ore	17.00
MS55	Antique Blue	15.00	MS252	Canary	17.00
MS56	Hyacinth	15.00	MS253	French Green	17.00
MS57	Cappuccino	15.00	MS254	Sea Foam	17.00
MS58	Pepperstone	15.00	MS255	Aqua Blue	17.00
MS59	Walnut	15.00	MS256	Light Mauve	17.00
MS60	Walnut Spice	15.00	MS257	Chocolate	17.00
MS62	Oatmeal	15.00	MS258	Antique Turquoise	17.00
MS63	Colonial White	15.00	MS259	Old Copper	17.00
MS64	Sunflower	15.00	MS260	Charcoal	17.00
MS65	Rusty Orange	15.00	MS261	Silk Black	17.00
MS66	Plum	15.00	MS262	Milky Way Blue	17.00
MS67	Semi-Clear Matte	15.00	MS263	Olive Leaf	17.00
MS68	Almond	15.00	MS264	Taupe	17.00
MS69	Almond Spice	15.00	MS265	Tangerine Ice	17.00
MS71	French Blue	15.00	MS266	Ruby Dust	17.00
MS72	French Gray	15.00	MS267	Milky Garnet	17.00
MS73	Grape	15.00			

Mid Fire Western Glazes

Code	Description	Pint
W4500	CLEAR GLOSS No ZINC	\$12.50
W4501	ROBINS EGG BLUE	\$14.00
W4502	PEACH GLOSS	\$14.00
W4503	MUSHROOM ART	\$14.00
W4504	DOVE GRAY SPECK	\$15.25
W4505	CORAL SPICE SPECK	\$14.00
W4506	BUBBLE GUM PINK	\$14.00
W4507	MIDNIGHT BLUE GLOSS	\$17.50
W4508	SPANISH MOSS ART	\$17.50
W4509	BURGUNDY GLOSS	\$20.00
W4510	BLACK GLOSS	\$17.50
W4511	LIGHT GREEN GLOSS	\$14.00
W4512	WHITE GLOSS	\$14.00
W4513	ORIBE GREEN	\$15.25
W4514	APRICOT GLOSS	\$15.25
W4515	ROSE GLOSS	\$14.00
W4516	CHOCOLATE CHIP	\$14.00
W4517	CINNAMON GLOSS	\$14.00
W4518	OATMEAL SPECK	\$14.00
W4519	PURPLE GLOSS	\$22.00
W4520	DOESKIN ART	\$15.25
W4521	CELADON GLOSS	\$14.00
W4522	GUNMETAL ART	\$20.00
W4523	PLUM GLOSS	\$20.00
W4524	DESERT MIST ART	\$17.50
W4525	DUSK BLUE GLOSS	\$17.50
W4526	WHITE MATT	\$14.00
W4527	BLUESTONE MATT	\$14.00
W4528	MOSS AGATE ART	\$14.00
W4529	NILE BLUE ART	\$17.50

Code	Description	Pint
W4530	AUTUMN GREEN ART	\$14.00
W4531	CORN SILK YELLOW	\$17.50
W4532	MIST BLUE ART	\$14.00
W4533	LAVA BROWN MATT	\$14.00
W4534	BISCAYNE BLUE MATT	\$14.00
W4536	PEARL GRAY GLOSS	\$17.50
W4537	MAGICAL MIST ART	\$14.00
W4538	BLUE JASPER ART	\$17.50
W4539	COBALT BLUE GLOSS	\$20.00
W4540	PUMPKIN GLOSS	\$20.00
W4541	CHERRY RED GLOSS	\$20.00
W4542	BRIGHT YELLOW GLOSS	\$20.00
W4543	BRIGHT RED MATT	\$20.00
W4544	PUMPKIN MATT	\$17.50
W4545	TRANSPARENT MATT	\$12.50
W4546	BLACK MATT	\$15.25
W4547	CHARTREUSE GLOSS	\$17.50
W4548	TURQUOISE PEACOCK	\$14.00
W4549	DELTA BLUE ART	\$17.50
W4550	TRANSPARENT GREEN	\$14.00
W4551	RUSTY ORANGE ART	\$15.25
W4552	TAHITIAN SUNSET ART	\$17.50
W4553	IRONWOOD ART	\$15.25
W4554	MYSTICAL JADE ART	\$15.25
W4555	KELP FOREST ART	\$14.00
W4556	OHATA RED ART	\$14.00
W4557	COPPER RED ART	\$14.00
W4558	GREEN RIVERSTONE	\$14.00
W4559	BLUE RIVERSTONE ART	\$14.00
W4560	FIRE OPAL ART	\$15.25
W4561	SUNSTONE ART	\$15.25
W4562	AVENTURINE ART	\$14.00
W4563	EGYPTIAN GOLD ART	\$20.00
W4564	ICEBERG DRIFT	\$14.00
W4565	VOLCANIC CRUST	\$14.00
W4566	ULTRA TURQUOISE	\$17.50
W4567	LEMONADE	\$15.25
W4568	ULTRAVIOLET	\$14.00
W4569	PAPAYA	\$17.50



Mid Fire Spectrum Glazes

Spectrum Stoneware Glazes

Opaque gloss high fire cone 5 glazes. A beautiful selection of opaque stoneware glazes with particular emphasis on bright primary colors.

Code	Description	Pint
S1100	Transparent	\$12.00
S1102	Wedgwood	\$13.00
S1103	Dusty Rose	\$13.50
S1104	Grass Green	\$12.50
S1106	Crimson	\$13.50
S1107	Black	\$12.50
S1108	Butter Yellow	\$12.50
S1109	Coral	\$12.50
S1110	Turquoise	\$12.50
S1111	Holly Green	\$13.50
S1112	Gold	\$17.50
S1113	Text. Milk & Honey	\$15.50
S1114	Gold Rain	\$17.50
S1115	Texture Moonscape	\$15.50
S1116	Mirror	\$17.50
S1117	Texture Chocolate	\$15.50
S1118	White	\$12.50
S1120	Satin Clear	\$12.50
S1121	Satin White	\$13.50
S1122	Satin Mottle	\$15.50
S1123	Satin Speckle	\$13.50
S1124	Satin Wedgwood	\$13.50
S1126	Satin Black	\$13.50
S1127	Satin Turquoise	\$13.50
S1129	Texture Oasis	\$13.50
S1131	Charcoal	\$13.50
S1132	Purple	\$17.50
S1134	Chocolate Brown	\$12.50
S1135	Navy Blue	\$17.50
S1136	Royal Blue	\$17.50
S1137	Teal Blue	\$13.50
S1138	Lime Green	\$13.50
S1140	Texture Kiwi Fruit	\$15.50
S1141	Texture Cascade	\$15.50
S1142	Texture Wheat	\$17.50
S1143	Texture Navy	\$19.50
S1144	Texture Mottle	\$13.50
S1145	Texture Autumn	\$13.50
S1146	Texture Swampy	\$17.50
S1147	Delft Blue	\$19.50
S1148	Texture Chowder	\$17.50
S1149	Oceanic Blue	\$17.50
S1151	Fuschia	\$17.50
S1152	Texture Chrome	\$19.50
S1153	Texture Cobalt	\$21.50
S1154	Texture Iron	\$17.50
S1155	Pebble Stone	\$15.50
S1156	Olive Stone	\$15.50
S1157	Texture Honey	\$17.50
S1158	Texture Bronze	\$19.50
S1159	Green Stone	\$15.50
S1161	Texture Topaz	\$17.50
S1162	Texture Burgundy	\$17.50
S1164	Dark Red	\$13.50
S1165	Bright Red	\$13.50
S1166	Bright Orange	\$13.50
S1167	Bright Green	\$13.50
S1168	Bright Purple	\$13.50
S1169	Dark Purple	\$13.50
S1170	Texture Mulberry	\$17.50
S1171	Texture Plum	\$17.50
S1172	Texture Leopard	\$17.50

Code	Description	Pint
S1173	Run. Hot Chowder	\$17.50
S1176	Cinnamon Ripple	\$15.50
S1177	Antique Mottle	\$15.50
S1180	Lagoon	\$15.50
S1181	Texture Cloud Burst	\$13.50
S1182	Texture Jungle	\$13.50
S1183	Texture Dark Cloud	\$15.50
S1184	Hunter Green	\$15.50
S1185	Forest Green	\$14.50
S1186	Soft Pink	\$14.50
S1187	Clear Crackle 3	\$12.50
S1188	Pewter	\$16.50
S1191	Muddy Waters	\$18.50
S1192	Reactive Purple	\$20.50
S1193	Fire Engine Red	\$14.50
S1194	Christmas Red	\$14.50
S1195	Neon Orange	\$14.50
S1196	Hot Pink	\$16.50
S1197	Reactive Red	\$18.50
S1198	Oil Spot	\$14.50
S1199	Texture Mossy	\$13.50



Spectrum Ash Glazes

Fires to Cone 4-6. Ash look glazes for electric kilns, designed to imitate the age old tradition of using ashes as a glaze in wood fired kilns. All six colors are translucent, and all are designed to "gather and run" much like a traditional ash glaze.

Code	Description	Pint
S1421	Pearl Ash	\$12.00
S1422	Fig Ash	\$12.00
S1423	Coffee Bean	\$12.00
S1424	Cactus Ash	\$12.00
S1425	Kiwi Ash	\$12.00
S1426	Blueberry Ash	\$12.00

Spectrum Cone 5 Shino

Fires to cone 5. Lead-free, non-toxic high fire glazes. Fire in oxidation Great colors and textures.

Code	Description	Pint
S1401	Cherry Salmon	\$16.00
S1402	Saffron	\$16.00
S1403	Citron	\$16.00
S1404	Wasabi	\$16.00
S1405	Blue Oyster	\$16.00
S1406	Ahi	\$16.00
S1407	Aubergine	\$16.00
S1408	Jalepeno	\$16.00
S1409	Guacamole	\$16.00
S1410	Miso	\$16.00
S1411	Nutmeg	\$16.00
S1412	Charcoal	\$16.00

Multi-Cone Glazes

Mayco Stoneware Glazes

Designed to perform from cones 5-10, in oxidation or reduction firing processes on stoneware clay body of choice. ... Whether it is a pairing with a Mayco Wash, one of our Clears or a complex surface like SW-127 Olivine, these layering techniques will improve the work of any clay enthusiast.

CODE	NAME	PINT	CODE	NAME	PINT
MSW100P	Blue Surf	\$14.25	MSW164P	Satin Patina	\$14.25
MSW101P	Stoned Denim	\$12.45	MSW165P	Lavender Mist	\$14.25
MSW104P	Black Walnut	\$12.45	MSW166P	Norse Blue	\$12.45
MSW105P	Frost Blue	\$12.45	MSW167P	Sand & Sea	\$12.45
MSW106P	Alabaster	\$12.45	MSW168P	Coral Sands	\$14.25
MSW107P	Dunes	\$12.45	MSW169P	Frosted Lemon	\$12.45
MSW108P	Green Tea	\$12.45	MSW170P	Blue Hydrangea	\$16.00
MSW109P	Capri Blue	\$12.45	MSW171P	Enchanted Forest	\$16.00
MSW110P	Oyster	\$12.45	MSW172P	Macadamia	\$12.45
MSW111P	Wrought Iron	\$12.45	MSW173P	Amber Quartz	\$12.45
MSW112P	Tiger's Eye	\$12.45	MSW174P	Leather	\$12.45
MSW113P	Speckled Plum	\$16.00	MSW175P	Rusted Iron	\$14.25
MSW115P	Midnight Rain	\$16.00	MSW176P	Sandstone	\$16.00
MSW116P	Robin's Egg	\$16.00	MSW177P	Raspberry Mist	\$16.00
MSW117P	Honeycomb	\$16.00	MSW178P	Fool's Gold	\$14.25
MSW118P	Sea Salt	\$16.00	MSW179P	Muddy Waters	\$14.25
MSW119P	Cinnabar	\$16.00	MSW180P	Desert Dusk	\$16.00
MSW120P	Northern Woods	\$12.45	MSW181P	Night Moth	\$16.00
MSW121P	Smoke	\$12.45	MSW182P	Antique Brass	\$16.00
MSW122P	Maycoshino	\$16.00	MSW183P	Oxblood	\$14.25
MSW123P	Sapphire	\$16.00	MSW184P	Speckled Toad	\$16.00
MSW125P	Purple Mint	\$16.00	MSW185P	Rainforest	\$14.25
MSW127P	Olivine	\$12.45	MSW186P	Azurite	\$16.00
MSW128P	Cordovan	\$14.25	MSW187P	Himalayin Salt	\$14.25
MSW129P	Copper Float	\$12.45	MSW188P	Landslide	\$14.25
MSW130P	Copper Jade	\$14.25	MSW189P	Cenote	\$16.00
MSW131P	Birch	\$12.45	MSW201P	Turquoise	\$12.45
MSW132P	Mirror Black	\$16.00	MSW203P	Root Beer Ice	\$12.45
MSW133P	Copper Ore	\$16.00	MSW204P	Amber Topaz Ice	\$12.45
MSW134P	Eggplant	\$16.00	MSW205P	Coral	\$16.00
MSW135P	Wintergreen	\$12.45	MSW210P	Emerald	\$16.00
MSW136P	Weathered Blue	\$12.45	MSW211P	Glacier Blue	\$14.25
MSW137P	Storm Gray	\$16.00	MSW212P	Peacock	\$12.45
MSW138P	Lemon Meringue	\$14.25	MSW250P	White Opal	\$16.00
MSW140P	Black Matte	\$16.00	MSW251P	Pink Opal	\$16.00
MSW141P	White Matte	\$14.25	MSW252P	Blue Opal	\$16.00
MSW142P	Gray Matte	\$14.25	MSW253P	Green Opal	\$16.00
MSW143P	Abalone	\$16.00	MSW255P	Gray Opal	\$16.00
MSW144P	Lava Rock	\$14.25	MSW401P	Mayco Light Flux	\$16.25
MSW145P	Tea Dust	\$14.25	MSW402P	Mayco Dark Flux	\$16.25
MSW146P	Aurora Green	\$16.00	MSW403P	White Mudcrack	\$16.25
MSW147P	Moonscape	\$16.00	MSW404P	Black Mudcrack	\$16.25
MSW147P	Moonscape	\$16.00	MSW405P	Light Magma	\$16.25
MSW148P	Lime Shower	\$16.00	MSW406P	Dark Magma	\$16.25
MSW149P	Crackle White	\$12.45	MSW501P	White Gloss	\$14.25
MSW150P	Celadon Bloom	\$16.00	MSW502P	Yellow Gloss	\$14.25
MSW151P	Olive Float	\$16.00	MSW503P	Orange Gloss	\$16.00
MSW152P	Blue Splatterware	\$16.00	MSW504P	Red Gloss	\$16.00
MSW153P	Indigo Rain	\$16.00	MSW505P	Purple Gloss	\$16.00
MSW154P	Shipwreck	\$16.00	MSW506P	Bright Blue Gloss	\$14.25
MSW155P	Winter Wood	\$16.00	MSW507P	Bright Green	\$14.25
MSW156P	Galaxy	\$16.00	MSW508P	Black Gloss	\$14.25
MSW158P	Lilac Matte	\$16.00	MSW509P	Dark Green Gloss	\$14.25
MSW162P	Pink Matte	\$14.25	MSW510P	Blue Gloss	\$14.25
			MSW147P	Moonscape	\$16.00

Multi-Cone Glazes

Mayco Stroke & Coat

Fires from cone 06 to cone 10, Stroke & Coat can be applied on wet clay or bisque, fired in oxidation or reduction and used in every decorative way imaginable. It is the ideal product of choice for the studio, classroom, potter, and fine artist.

CODE	NAME	2 oz.	PINT
SC-1	Pink-A-Boo	4.35	19.75
SC-2	Melon-choly	4.35	19.75
SC-3	Wine About It	4.35	19.75
SC-5	Tiger Tail	4.35	19.75
SC-6	Sunkissed	4.35	19.75
SC-7	Leapin' Lizard	4.35	19.75
SC-8	Just Froggy	4.35	19.75
SC-9	Jaded	4.35	19.75
SC-10	Teal Next Time	4.35	19.75
SC-11	Blue Yonder	4.35	19.75
SC-12	Moody Blue	4.35	19.75
SC-13	Grapel	4.35	19.75
SC-14	Java Bean	4.35	19.75
SC-15	Tuxedo	4.35	19.75
SC-16	Cotton Tail	4.35	19.75
SC-17	Cheeky Pinky	4.35	19.75
SC-18	Rosey Posey	4.35	19.75
SC-20	Cashew Later	4.35	19.75
SC-23	Jack O'Lantern	4.35	19.75
SC-24	Dandelion	4.35	19.75
SC-25	Crackerjack Brn	4.35	19.75
SC-26	Green Thumb	4.35	19.75
SC-27	Sour Apple	4.35	19.75
SC-28	Blue Isle	4.35	19.75
SC-29	Blue Grass	4.35	19.75
SC-30	Blue Dawn	4.35	19.75
SC-31	The Blues	4.35	19.75
SC-32	Bluebeard	4.35	19.75
SC-33	Fruit of the Vine	4.35	19.75
SC-34	Down to Earth	4.35	19.75
SC-35	Gray Hare	4.35	19.75
SC-36	Irish Luck	4.35	19.75
SC-37	Ivory Tower	4.35	19.75
SC-39	Army Surplus	4.35	19.75
SC-40	Blueberry Hill	4.35	19.75
SC-41	Brown Cow	4.35	19.75
SC-42	Butter Me Up	4.35	19.75
SC-43	Lettuce Alone	4.35	19.75
SC-45	My Blue Heaven	4.35	19.75
SC-46	Rawhide	4.35	19.75
SC-48	Camel Back	4.35	19.75
SC-50	Orange Ya Happy	4.35	19.75
SC-51	Poo Bear	4.35	19.75
SC-52	Toad-ily Green	4.35	19.75
SC-53	Purple Haze	4.35	19.75
SC-54	Vanilla Dip	4.35	19.75
SC-55	Yella Bout It	4.35	19.75
SC-58	501 Blues	4.35	19.75
SC-60	Silver Lining	4.35	19.75
SC-65	Peri-Twinkle	4.35	19.75

CODE	NAME	2 oz.	PINT
SC-70	Pink-A-Dot	4.35	19.75
SC-71	Purple-licious	4.35	19.75
SC-72	Grape Jelly	4.35	19.75
SC-73	Candy Apple Red	4.35	19.75
SC-74	Hot Tamale	4.35	19.75
SC-75	Orange-A-Peel	4.35	19.75
SC-76	Cara-bein Blue	4.35	19.75
SC-77	Glo-Worm	4.35	19.75
SC-78	Lime Light	4.35	19.75
SC-79	It's Sage	4.35	19.75
SC-80	Basketball	4.35	19.75
SC-81	Cinnamon Stix	4.35	19.75
SC-83	Tip Taupe	4.35	19.75
SC-85	Orkid	4.35	19.75
SC-86	Old Lace	4.35	19.75
SC-87	Ruby Slippers	4.35	19.75
SC-88	Tu Tu Tango	4.35	19.75
SC-89	Cutie Pie Coral	4.35	19.75
SC-90	Elephant Ears	4.35	19.75
SC-91	Seabreeze	4.35	19.75
SC-92	Café Olé	4.35	19.75
SC-93	Honeydew List	4.35	19.75
SC-95	Pinkie Swear	4.35	19.75
SC-96	Aqu-ward	4.35	19.75
SC-97	Cant-elope	4.35	19.75
SC-95	Pinkie Swear	4.35	19.75



Mayco Foundations Matte

Fires to cone 06 to 6. Creates a soft, subdued finish. Apply with a fan brush, fully loading brush and brushing in one direction to minimize brush marks. Matte finish will increase in glossiness if fired higher than cone 6. Certified AP non-toxic and foodsafe.

CODE	NAME	PINT
FN-301	Marshmallow White	13.50
FN-302	Ivory Cream	13.50
FN-304	Black Velvet	13.50
FN-305	Milk Chocolate	13.50
FN-306	Pumpkin Tart	13.50

Multi-Cone Glazes

Mayco Stoneware Ice

Fires to cone 6-10. Translucent, Celadon-like. Use on textured surfaces, in combination with other Stoneware glazes, Mayco Flux, Underglazes, Silk-screens or over Designer Liner.

CODE	NAME	PINT
SW-201	Turquoise	12.45
SW-203	Root Beer	12.45
SW-204	Amber Topaz	12.45
SW-205	Coral	16.00
SW-206	Melon	16.00
SW-207	Chambray	16.00
SW-209	Charcoal	16.00
SW-210	Emerald	16.00
SW-211	Glacier Blue	14.25
SW-212	Peacock	12.45

Leslie's Engobe & Happy

Fires to cone 06-5. Ideal for decorating tiles, pottery or sculpture.

CODE	NAME	PINT
HP 1	Snowdrift	\$10.00
HP 2	Black Panda	\$14.00
HP 3	Whale Grey	\$11.00
HP 4	Donkey Brown	\$14.00
HP 5	Grasshopper Green	\$13.00
HP 6	Tahiti Teal	\$12.00
HP 7	Mint Green	\$11.00
HP 8	Pinata Purple	\$18.00
HP 9	Blue Moon	\$12.00
HP 10	King Tut Turquoise	\$13.00
HP 12	Salmon Head Pink	\$18.00
HP 14	Pumpkin Head	\$16.00
HP 15	Submarine Yellow	\$14.00
H101	Happy Clear	\$9.58
H102	Ink Black	\$12.01
H103	Egg White	\$12.41
H104	Blue Eyes	\$11.44
H105	Pepper Red	\$12.63
H106	Volcano Orange	\$12.56
H107	Corn Cob Yellow	\$13.53
H108	Water Mellon Green	\$11.71
H109	Blue Jeans	\$11.77
H110	Sea Foam	\$11.21
H111	Sea Weed Green	\$11.43

Mayco Flux & Washes

CODE	NAME	Price
MSW401	Light Flux Pint	\$5.00
MSW402	Dark Flux Pint	\$5.00
MSW301	Iron SW Wash 2 oz.	\$4.50
MSW302	Rutile SW Wash 2 oz.	\$4.50
MSW303	Manganese SW Wash 2 oz.	\$4.50
MSW304	Copper SW Wash 2 oz.	\$4.50
MSW305	Cobalt SW Wash 2 oz.	\$4.50

Mayco Stoneware Opal

Fires to cone 6-10. A glaze that 'breaks,' emphasizing textural features.

CODE	NAME	PINT
SW-250	White Opal	16.00
SW-251	Pink Opal	16.00
SW-252	Blue Opal	16.00
SW-253	Green Opal	16.00
SW-255	Gray Opal	16.00

Mayco Stoneware Clear

Fires to cone 6-10. All Mayco Stoneware Clear glazes are AP Non-Toxic, Food Safe and Dinnerware Safe, when used according to manufacturer's directions.

CODE	NAME	Price
SW-001	Clear Pint	12.25
SW-001	Clear Gallon	n/a
SW-002	Matte Clear Pint	12.25
SW-002	Matte Clear Gallon	n/a
SW-003	Crackle Matte Clear Pint	12.25
SW-003	Crackle Matte Clear Gal	n/a
SW-004	Zinc-Free Clear Pint	12.25
SW-004	Zinc-Free Clear Gal	n/a

Mayco Designer Liners



Fires to Cone 06-6. Concentrated pigment to use over and under nonmoving glazes and each other. Will fire matte without a clear glaze over it.

Code	Description	1.25oz
SG 401	Black	5.00
SG 402	White	5.00
SG 403	Red	5.00
SG 402	Blue	5.00
SG 405	Green	5.00
SG 406	Brown	5.00
SG 407	Yellow	5.00
SG 408	Orange	5.00
SG 409	Bright Green	5.00
SG 410	Bright Blue	5.00

Fires to cone 6-10. Mayco SW-401 Light Flux and SW-401 Dark Flux is Fires to cone 6-10. a flowing glaze intended for use with other Stoneware Glazes to enhance movement and promote reactions for interesting effects.

Multi-Cone Glazes

Mayco Foundations

Cone 06, many can go to cone 6, check individual labels. Foundations Opque is high gloss & can be mixed together. Dries fast for same-day firing. Can apply to leatherhard clay, allowing an open area for out-gassing during firing. Foundations Sheer are translucent glazes that allow surface textures to show through. Certified AP non-toxic & Food Safe. Testing recommended.



CODE	NAME	PINT
FN-001	White	13.50
FN-002	Yellow	13.50
FN-003	Orange	13.50
FN-004	Red	13.50
FN-005	Pink	13.50
FN-006	Blue	13.50
FN-007	Green	13.50
FN-008	Brown	13.50
FN-009	Black	13.50
FN-010	Tree Green	13.50
FN-011	Light Blue	13.50
FN-012	Lavender	13.50
FN-013	Light Yellow	13.50
FN-014	Antique White	13.50
FN-015	Brick Red	13.50
FN-016	Harvest Orange	13.50
FN-017	Purple	13.50
FN-018	Bright Blue	13.50
FN-019	Dark Blue	13.50
FN-020	Medium Green	13.50
FN-021	Olive Green	13.50
FN-022	Tan	13.50
FN-023	Cinnamon	13.50
FN-024	Gray	13.50
FN-025	Raspberry Whip	13.50
FN-027	Glade Green	13.50
FN-028	Wisteria Purple	13.50
FN-029	Rich Chocolate	13.50
FN-031	Corn Flower Blue	13.50
FN-032	Canton Jade	13.50
FN-033	Mediterranean Teal	13.50
FN-034	Big Sky Blue	13.50
FN-035	Deep Red	13.50
FN-036	Grape	13.50
FN-037	Chartreuse	13.50
FN-038	Sand	13.50
FN-039	Light Gray	13.50
FN-040	Pumpkin	13.50
FN-041	Medium Blue	13.50
FN-042	Teal Blue	13.50
FN-043	Bright Jade	13.50
FN-044	Yellow-Orange	13.50
FN-045	Taupe	13.50
FN-046	Sage	13.50
FN-047	Light Pink	13.50
FN-048	Bright Pink	13.50
FN-049	Flamingo	13.50

FN-051	Strawberry	13.50
FN-052	Tangerine	13.50
FN-053	Mint	13.50
FN-054	Pistachio	13.50
CODE	NAME	PINT
FN-201	Golden Clear	13.50
FN-202	Yadro	13.50
FN-203	Dry Champagne	13.50
FN-204	Mudpuddle Brown	13.50
FN-205	Saddle Tan	13.50
FN-207	Orange Slice	13.50
FN-209	Floral Pink	13.50
FN-211	Sheer Blue	13.50
FN-212	Blue Diamond	13.50
FN-213	Saffire Blue	13.50
FN-214	Pastel Jade	13.50
FN-216	Sea Glass	13.50
FN-220	Sooty Grey	13.50
FN-221	Milk Glass White	13.50
FN-230	Poppy	13.50
FN-231	Clearly Jade	13.50
FN-201	Golden Clear	13.50
FN-202	Yadro	13.50
FN-203	Dry Champagne	13.50
FN-204	Mudpuddle Brown	13.50
FN-205	Saddle Tan	13.50
FN-206	Lemon Ice	13.50
FN-207	Orange Slice	13.50
FN-208	Crystal Coral	13.50
FN-209	Floral Pink	13.50
FN-211	Sheer Blue	13.50
FN-212	Blue Diamond	13.50
FN-213	Saffire Blue	13.50
FN-214	Pastel Jade	13.50
FN-216	Sea Glass	13.50
FN-220	Sooty Grey	13.50
FN-221	Milk Glass White	13.50
FN-222	Indigo	13.50
FN-223	Amethyst	13.50
FN-224	Key Lime	13.50
FN-225	Watermelon	13.50
FN-226	Sooty Grey	13.50
FN-227	Milk Glass White	13.50
FN-228	Slate Grey	13.50
FN-229	Iced Mocha	13.50
FN-230	Poppy	13.50
FN-231	Clearly Jade	13.50

High Fire Glazes

Spectrum High Fire Glazes

Fires to cone 9-10.
Spectrum 1200 series, clear
gloss glaze appropriate for
use at cone 9/10. Lead free,
dinnerware safe, and A/P
non-toxic.



Code	Description	Pint
S1200G	Transparent	40.00
S1200	Transparent	\$11.00
S1201	Satin Crackle	\$11.00
S1207	Turquoise	\$11.00
S1209	Black	\$12.50
S1210	White	\$11.00
S1211	Mustard	\$12.50
S1212	Light Blue	\$11.00
S1213	Spring Green	\$11.00
S1214	Grass Green	\$11.00
S1215	Ruby	\$12.50
S1221	Texture Oatmeal	\$11.00
S1222	Cinnamon Lava	\$14.50
S1225	Texture Honey	\$11.00
S1227	Texture Emerald	\$11.00
S1228	Texture Grey	\$12.50
S1229	Blue	\$13.00
S1234	Texture Seafoam	\$13.00
S1235	Texture Blue	\$13.00
S1237	Satin Black	\$13.00
S1243	Teal	\$11.00
S1244	Sky Blue	\$11.00
S1254	Yellow	\$11.00
S1263	Blue Lava	\$14.50
S1269	Orchid Lava	\$18.50
S1273	Bright Green	\$12.50
S1276	Fire Engine Red	\$12.50
S1277	Christmas Red	\$12.50
S1278	Neon Orange	\$12.50
S1279	Hot Pink	\$18.00

Tom Coleman Dry Showcase Glazes

This series includes some of the best glazes used by world famous potter Tom Coleman. These glazes were developed and refined by Tom during the last 32 years he has been making a living creating in clay. All glazes require cone 10 reduction firing. Lead free.

#	Color	5lb.	10 lb.	50lb.
TC101	Decoration Base White	1.34	1.09	0.77
TC102	White Chun	2.34	1.84	1.33
TC103	Clear Base	1.73	1.39	1.00
TC104	Tea Dust Black	1.34	1.09	0.77
TC105	Jet Black	5.23	4.20	3.02
TC106	Green to Black Satin Matt	3.78	3.04	2.17
TC107	Copper Teal	2.78	2.26	1.62
TC108	Vegas Red	3.56	2.87	2.06
TC109	Lipstick Purple	3.56	2.87	2.06
TC111	Desert Sand	5.12	4.09	2.99
TC112	Tortoise Shell	2.23	1.77	1.28
TC112	Tortoise Shell	2.23	1.77	1.28
TC114	Fake Ash	6.12	4.89	3.48
TC115	Non Iron Blue Celadon	2.34	1.84	1.34

Underglazes

Speedball Underglazes

Code	Volume	2 oz.	CODE	Description	Pint
SB1000	White	5.18	SB1050	White	15.77
SB1001	Cream	5.18	SB1051	Cream	15.77
SB1002	Yellow	5.71	SB1052	Yellow	18.13
SB1003	Yellow/Orange	6.27	SB1053	Yellow/Orange	21.42
SB1004	Melon	6.27	SB1054	Melon	21.42
SB1005	Pink	5.71	SB1055	Pink	18.13
SB1006	Royal Blue	7.21	SB1056	Royal Blue	25.7
SB1007	Med Blue	5.18	SB1057	Med Blue	15.77
SB1008	Sky Blue	5.18	SB1058	Sky Blue	15.77
SB1009	Turquoise	5.18	SB1059	Turquoise	15.77
SB1010	Aqua	5.18	SB1060	Aqua	15.77
SB1011	Chartreuse	5.18	SB1061	Chartreuse	15.77
SB1012	Medium Green	5.71	SB1062	Medium Green	18.13
SB1013	Pine	5.18	SB1063	Pine	15.77
SB1014	Tan	5.18	SB1064	Tan	15.77
SB1015	Brown	5.18	SB1065	Brown	15.77
SB1016	Black	6.27	SB1066	Black	21.42
SB1017	Gray	5.18	SB1067	Gray	15.77
SB1018	Sea Blue	5.18	SB1068	Sea Blue	15.77
SB1019	Orange	7.21	SB1069	Orange	25.7
SB1020	Red	8.16	SB1070	Red	29.13
SB1021	Burgundy	8.16	SB1071	Burgundy	29.13
SB1022	Purple	7.21	SB1072	Purple	25.70
SB1023	Violet	7.21	SB1073	Violet	25.7
SB1024	Soft Pink	5.71	SB1074	Soft Pink	18.13
SB1025	Carmine	7.21	SB1075	Carmine	25.70
SB1026	Flame Red	7.21	SB1076	Flame Red	25.70
SB1027	Mandarin Orange	7.21	SB1077	Mandarin	25.70
SB1028	Peach	6.27	SB1078	Peach	21.42
SB1029	Saffron Yellow	6.27	SB1087	Saffron Yellow	21.42
SB1030	Leaf Green	5.71	SB1088	Leaf Green	18.13
SB1031	Avocado	5.71	SB1089	Avocado	22.44
SB1032	Teal	5.18	SB1090	Teal	15.77
SB1033	Blue Frost	5.18	SB1091	Blue Frost	15.77
SB1034	Amethyst	7.21	SB1092	Amethyst	25.70
SB1035	Royal Purple	7.21	SB1093	Royal Purple	25.70

Underglazes

AMACO Velvet Underglazes

Fires cone 06-10. AMACO Velvet semi-translucent underglazes offer two finish possibilities. Left unglazed, they have the appearance of velour or velvet. They will assume a soft satin matte finish when glazed with a transparent matte glaze and will intensify when covered with a transparent gloss glaze. Email for prices and availability on Gallons!

Code	Description	2 oz	Pint
V-301	Ivory Beige	7.25	28.00
V-303	Terra Cotta	7.25	28.00
V-304	Straw	7.25	28.00
V-308	Yellow	7.25	28.00
V-309	Deep Yellow	7.25	28.00
V-313	Red Brown	7.25	28.00
V-314	Chocolate Brown	7.25	28.00
V-315	Peach	7.25	28.00
V-316	Light Pink	7.25	28.00
V-317	Coral	7.25	28.00
V-318	Rose	7.25	28.00
V-320	Lavender	9.00	40.00
V-321	Lilac	7.25	28.00
V-322	Purple	7.25	28.00
V-323	Salmon	7.25	28.00
V-324	Blush	7.25	28.00
V-325	Baby Blue	7.25	28.00
V-326	Med Blue	7.25	28.00
V-327	Turquoise Blue	7.25	28.00
V-332	Teal Blue	7.25	28.00
V-333	Avocado	7.25	28.00
V-336	Royal Blue	10.25	58.00
V-341	Blue Green	7.25	28.00
V-343	Chartreuse	7.25	28.00
V-345	Light Green	7.25	28.00
V-347	Pistachio	7.25	28.00
V-349	Cactus	7.25	28.00
V-350	Orange	7.25	28.00
V-353	Dark Green	7.25	28.00
V-354	Leaf Green	7.25	28.00
V-356	Pearl Gray	7.25	28.00

Code	Description	2 oz	Pint
V-359	Ultra White	9.00	40.00
V-360	White	7.25	28.00
V-361	Jet Black	7.25	28.00
V-362	Ultra Black	9.00	40.00
V-362	Morning Fog	9.00	40.00
V-364	Elephant	10.25	58.00
V-365	Slate	10.25	58.00
V-366	Teddy Bear Brown	7.25	28.00
V-370	Velour Black	9.00	40.00
V-372	Mint Green	7.25	28.00
V-375	Maroon	10.25	58.00
V-376	Hunter Green	7.25	28.00
V-379	Ultra Violet	10.25	58.00
V-380	Violet	10.25	58.00
V-381	Amethyst	10.25	58.00
V-382	Red	10.25	58.00
V-383	Light Red	10.25	58.00
V-384	Real Orange	10.25	58.00
V-385	Cinnamon	7.25	28.00
V-386	Electric Blue	7.25	28.00
V-387	Bright Red	10.25	58.00
V-388	Radiant Red	10.25	58.00
V-389	Flame Orange	10.25	58.00
V-390	Bright Orange	10.25	58.00
V-391	Intense Yellow	10.25	58.00

Coyote High Fire Underglazes

Fires cone 6-10. The colors can be mixed, and stay true and stable up to cone 10 in oxidation. They are always bold and striking, and are suited to functional ware when covered in Coyote Gloss Clear and fired to cone 6. They can be used on either greenware or bisque.

Code	Description	4 oz	Pint
CUG001	Black	6.80	18.30
CUG002	Blue Green	7.50	21.70
CUG003	Brown	6.30	15.80
CUG004	Cactus Green	6.60	17.40
CUG005	Cinnamon	6.10	15.30
CUG006	Dark Brown	6.30	15.90
CUG007	Lavender	7.50	20.50
CUG008	Light Blue	6.50	17.30
CUG009	Mazer. Blue	7.60	22.00
CUG010	Orange	8.80	26.50
CUG011	Pink	6.70	17.80
CUG013	Red	11.50	36.60
CUG014	Red Orange	8.20	23.90
CUG015	Sage Green	8.10	23.90
CUG016	Sky Blue	6.60	17.60
CUG017	White	5.70	12.90

Code	Description	4 oz	Pint
CUG018	Yellow	8.20	23.00
CUG019	Yellow Orng	6.30	15.80
CUG020	Blue Pansy	8.20	23.00
CUG021	Buttercup	9.50	28.60
CUG022	Powder Blue	6.10	15.30
CUG023	Royal Blue	6.70	18.60
CUG024	Tangerine	8.80	25.70
CUG025	Really Red	11.50	36.60
CUG026	Violet	12.20	40.30
CUG027	Burgundy	9.80	29.80
CUG028	Evergreen	6.30	15.90
CUG029	Hunter Green	6.40	16.10
CUG030	Olive	7.60	22.00
CUG031	Sea Grass	7.20	20.50

Underglazes

Leslie's U-Series Underglazes

Fires to cone 06-5. The opaque colors work well for hard edge designs such as painting signs, murals, tile projects, pottery, or sculpture. Best when applied to dry greenware, and can also be applied to bisque ware. Can be used for one stroke decoration, silk screening, sponge-stippling, or painting on damp or dry clay. Lead Free - Dinnerware Safe

Code	Description	Pint	Code	Description	Pint
U-1	Maroon Red	\$24.00	U-26	Chiffon	\$13.00
U-3	Dark Brown	\$14.00	U-27	Key Lime Green	\$16.00
U-4	Medium Brown	\$15.00	U-28	Periwinkle	\$13.00
U-5	Dark Navy Blue	\$15.00	U-29	Chocolate brown	\$23.00
U-6	Medium Blue	\$13.00	U-30	Soft Petal Pink	\$13.00
U-7	Yellow	\$20.00	U-31	Cantaloupe Orange	\$20.00
U-8	White	\$9.00	U-32	Buttercup Yellow	\$14.00
U-9	Black	\$20.00	U-33	Salmon Pink	\$18.00
U-10	Turquoise	\$17.00	U-34	Cancun Blue	\$14.00
U-11	Light Blue	\$19.00	U-35	Wisteria	\$13.00
U-12	Blue Green	\$19.00	U-36	Vanilla	\$12.00
U-13	Pink	\$15.00	U-37	Desert Sand	\$12.00
U-14	Grey	\$11.00	U-38	Wicker	\$16.00
U-16	Chartreuse	\$21.00	U-39	Raspberry Grey	\$14.00
U-17	Dark Green	\$16.00	U-41	Sequoia Green	\$12.00
U-19	Orange	\$19.00	U-42	Aztec Blue	\$13.00
U-20	Lavender	\$16.00	U-43	Mint Sherbet	\$13.00
U-21	Canary	\$20.00	U-44	Dark Celadon	\$12.00
U-22	Purple	\$23.00	U-45	Sherbet Orange	\$17.00
U-23	New Red	\$21.00	U-60	Hot lips Red	\$16.00
U-24	Basic Black	\$12.00			
U-25	Scarlet	\$34.00			

Leslie's Squeeze Pen Underglazes

Fire to Cone 05-10. Ideal for detailed writing, drawing, decorating. Can be used in conjunction with Leslie glazes or underglazes when outlining is needed. Drip resistant opaque colors that hold their line without blurring or bleeding when applied on top of or under a glaze.

Code	Description	2 oz
SQ-100	Black	\$11.25
SQ-150	White	\$11.25
SQ-350	Pink	\$11.25
SQ400	Red	\$11.25
SQ450	Orange	\$11.25
SQ500	Yellow	\$11.25
SQ600	Light Green	\$11.25
SQ800	Dark Blue	\$11.25



UNDERGLAZE CRAYONS
For sketching on bisque-ware. Colors can be blended by rubbing. Use a wet brush for a Watercolor effect.
CHKCR \$49/set
CHKIND \$5.60/ea.

AMACO UNDERGLAZE PENCILS

Underglaze Decorating Pencils are ideal for shading, fine line drawing, or identification. Apply the underglaze pencil to bisque ware to create a variety of unique decorative designs.

Available in Black, Green, Brown, Rose, Blue, and Yellow.
UGP \$18.50/ea.



Set 208

Turquoise
Rose
Brown
Black
Yellow
Dark Blue
Dark Green
White

Set 209

Lilac
Gray
Light Brown
Dark Brown
Yellow-Green
Medium Green
Blue-Green
Medium Blue

Underglaze Products

UNDERGLAZE WATERCOLOR PAINT SETS

AMACO Semi-Moist Underglaze Decorating Colors are suitable for many types of ceramic painting. They are especially good for water color effects and painting fine details. The 24 colors are concentrated, intense and opaque. Additional shades and tints are made by mixing. Colors may be brushed on either greenware or bisqueware.

Many colors available in 4 different 8-color sets.

AM108, AM109, AM110, AM111 \$46.00/each set

Set 108

Maroon
Light Yellow
Dark Blue
Blue Green
Dark Green
Black
Light Brown
White

Set 109

Turquoise
Lilac
Medium Blue
Pink
Warm Gray
Mahicans Brown
Bright Yellow
Irish Green

Set 110

Purple
Light Blue
Aqua
Rose
Orange
Peach
Chartreuse
Sun Tan

Set 111

Red
Light red
Real Orange
Electric Blue
Amethyst
Violet
Hunter Green
Salmon



MINNESOTA CLAY GRAFFITO PAPER SETS

The principle behind Graffito Transfer Paper is exactly the same as carbon paper. Graffito sheets are embedded with a ceramic underglaze that will transfer to ceramic when drawn upon using a pen or a pencil. This means that everything from photographic newspaper images to original drawings can be transferred to ceramic.

Graffito is available in six colors: Black, Green, Blue, Teal, Brown and Rose. All colors except Rose can be fired from cone 06 to cone 8. Each sheet is a nine inches square. The sheets are flexible enough to be used on thrown or cast ware. However the medium is ideally suited for flat items like tiles, plates and trivets.

UGGKIT Set of six \$20.95

HIGH TEMP CHINA MARKER

Wax-based. Brown. Cone 10.
CMP \$3.95



POTTER'S PADS

Underglaze stamping inks in eight colors. Use regular rubber stamps or printing blocks to transfer your designs. Fire from cone 06 to cone 8.

Colors are Black, Blue, Brown, Green, Teal, Gold, White, & Red

PPAD \$16.99/ea.



CHOXIL UNDERGLAZE PENCILS

Choxils are a solid underglaze drawing medium like a pencil with the density of a pencil. Can be sharpened in most pencil sharpeners. Apply to bisque ware. All colors are stable to Cone 8 except Rose, which is stable to Cone 4. Kit comes with each of the 10 different colors. AP (Non-Toxic)

Choxil Each \$7.95
CK Set of ten \$41.99



Glaze Products & Lusters

Lusters

DUNCAN PRECIOUS METALS

Fires to cone 018-022.

Actual precious metals which, when fired, yield different shades ranging from yellow-gold to white-gold.

Code	Description	2 Gram
DOG801	Bright Gold	36.00
DOG802	White Gold	36.00
DOG805	Premium Gold	55.00
DOG803	Mother Pearl 1.5 oz	7.00
DOA901	Essence	6.00



Wax resist: apply to greenware or bisque to "resist" application of glaze, slip and underglaze. Non Toxic.

This wax emulsion, when applied on greenware or bisque as a method of decoration, "resists" application of glaze, slip and underglaze. Available in pint or gallon jars.

Wax Resist now has a coloring agent to make it easier to see during application. The color will burn off during firing.

Texturizer & Wax



TH-1 is a rutile based texturizer. When layered with other glazes it produces a floating, flowing texture.

Apply TL-1 Texturizer over any Cone 05 glaze to create different textures. Surface textures vary depending on the type of base glaze (gloss, matte, or textured), broadening the glaze palette tremendously. An even wider variety of effects can be achieved by applying TL-1 between coats of two different Cone 05 glazes.

Code	Description	Pint
TH-1	Hi Fire Texturizer	15.00
TL-1	Low Fire Texturizer	18.00
SUS	Suspendaid	13.50
BFIX	Bisque Fix	29.00
AWP	Green Wax Pint	23.40
AWG	Green Wax Gallon	107.40
GUM	Amaco Gum Solution	9.40
LATEX	Green Wax Gallon	44.00

Raku Glazes

Spectrum Raku Glazes

Code	Description	Pint
S850	Raku Clear	\$14.00
S851	Raku White	\$14.00
S852	Raku Turquoise	\$17.00
S853	Raku Cobalt Blue	\$19.00
S855	Raku Emerald	\$16.00
S861	Raku Metallic Flash	\$19.00
S862	Raku Galaxy	\$20.00
S863	Raku Nebula	\$22.00
S864	Raku Sunspot	\$23.00
S865	Raku Mars	\$19.00
S866	Raku Deep Space	\$19.00
S870	Raku Starry Night	\$26.00
S871	Raku Yellow	\$16.00
S872	Raku Orange	\$16.00
S873	Raku Red	\$36.00

Code	Description	Pint
S874	Raku Lime	\$24.00
S875	Raku Algae Bloom	\$24.00
S878	Raku Cosmic Copper	\$26.00
S880	Raku Armadillo	\$17.00
S881	Raku Oxblood	\$26.00
S882	Raku Orchid Pink	\$17.00
S883	Raku Amethyst	\$20.00
S884	Raku Aqua	\$16.00
S885	Raku Blue Topaz	\$16.00
S886	Raku Lapis	\$16.00
S887	Raku Neptune	\$19.00
S888	Raku Cassiopeia	\$26.00
S889	Raku Andromeda	\$26.00
S890	Raku Chimera	\$24.00
S891	Raku Northern Lights	\$17.00

Laguna Dry Glazes

Prices are per bag, based on per pound price.

Code	Color	Cone	1lb.	5lb.	10 lb.	50lb.
EM1050	Clear	06	6.75	31.86	58.17	256.23
MSD29	Clear Bright	5	9.59	42.40	77.40	341.00
MSD67	Clear Matte	5	4.08	18.05	33.00	145.00
MSD63	Colonial White Gloss	5	8.80	38.95	71.10	313.50
WC558	Jon's Clear	5-10	8.90	35.31	64.47	283.98
WC561	Crystal Palace	10	8.90	35.31	64.47	283.98

Raku & Dry Glaze

Laguna Dry Raku Glazes

Prices are by the pound.

Lead free and developed just for Raku firing. Add water to the glaze and mix to the consistency of thin paint. Do not screen the liquid. Dip, pour or brush onto pottery.



Code	Color	1lb.	5lb.	10 lb.	50lb.
R1D	White Matt	1.99	2.06	1.84	1.40
R2D	Tutti Frutti	1.99	2.26	2.03	1.69
R8D	Soda	-	2.92	2.66	2.39
R9D	Begs	-	1.64	1.39	1.34
R10D	Bright Buff	-	2.18	1.94	1.48
R11D	Borax	-	2.55	2.32	2.09
R12D	Blackfoot	-	4.40	4.00	3.60
R13D	Copper	-	3.48	3.17	2.85
R14D	Lithium Slip	-	13.24	12.03	10.83
R15D	Dark Red	-	3.43	3.12	2.81
R19D	Cornwall Stone	-	1.85	1.68	1.51
R20D	Raku Burst	-	3.24	2.94	2.65
R21D	Bronze	-	9.00	8.50	8.00
R22D	Awabi Shell	5.00	4.66	4.54	4.20
R23D	Uquisi Nightingale	3.02	4.66	4.24	3.82
R24D	Dynasty Blue	-	4.88	4.43	3.99
R25D	Black Lacquer	-	8.11	7.38	6.64
R26D	Kingin Gold Silver	-	4.59	4.18	3.76
R27D	Shinju	-	5.54	5.04	4.54

Amaco Raku

Code	Color	Pint
AR10	Clear Crackle	\$18.50
AR11	White Crackle	\$18.50
AR12	Blue Bell	\$18.50
AR13	Smokey Blue	\$18.50
AR14	Smokey Lilac	\$18.50
AR15	Caribbean Blue	\$18.50
AR17	Tarnished Silver	\$18.50
AR19	Copper Matte	\$18.50
AR20	Red Crackle	\$18.50



These glazes react best when fired to 05 and reduced after firing.

Tom Coleman Dry Showcase Glazes

This series includes some of the best glazes used by world famous potter Tom Coleman. These glazes were developed and refined by Tom during the last 32 years he has been making a living creating in clay. All glazes require cone 10 reduction firing. Lead free.

#	Color	5lb.	10 lb.	50lb.
TC101	Decoration Base White	1.34	1.09	0.77
TC102	White Chun	2.34	1.84	1.33
TC103	Clear Base	1.73	1.39	1.00
TC104	Tea Dust Black	1.34	1.09	0.77
TC105	Jet Black	5.23	4.20	3.02
TC106	Green to Black Satin Matt	3.78	3.04	2.17
TC107	Copper Teal	2.78	2.26	1.62
TC108	Vegas Red	3.56	2.87	2.06
TC109	Lipstick Purple	3.56	2.87	2.06
TC111	Desert Sand	5.12	4.09	2.99
TC112	Tortoise Shell	2.23	1.77	1.28
TC112	Tortoise Shell	2.23	1.77	1.28
TC114	Fake Ash	6.12	4.89	3.48
TC115	Non Iron Blue Celadon	2.34	1.84	1.34



Dry Glaze Tip

Izzy
Operations Manager

Dry glazes are less expensive and more versatile than liquid glazes. They can be easily adjusted for different application methods, whether it be dipping, spraying, or brushing.

We have a free fact sheet available to help!

Mold Making Supplies

MOLD STRAPS

Universal banding straps with fastener lock. Low tension, release with ease. Available in lengths from 30 inches to 12 feet. All straps are 1 inch wide and made from 1000 pound test nylon.



Length	Color	Each
3 ft.	Yellow	9.30
4 ft.	Green	10.20
5 ft.	Blue	11.10
6 ft.	Orange	12.00
7 ft.	Red	13.80

PURE LUBE

Concentrated mold soap to easily release original from plaster molds.
One Pint **\$4.99**

RUBBER BANDS (UV)

Heavy duty bands for molds. Resistant to ultra violet light.

CODE	Length	Each	1 Lb. Bag
MBANDS4	4"	1.35	21.10
MBANDS5	5"	1.35	21.10
MBANDS6	6"	1.35	21.10
MBANDS7	7"	1.35	21.10
MBANDS8	8"	1.35	8.95
BANDS	various	1.35	n/a



Plaster Use

Doug Johnson
President/Owner

Ask us to help you find the plaster to fit your specific needs. We have the largest selection of USG plasters in Northern California.

We also have lots of free literature that contains specifications, mixing instructions and other valuable information.

USG's web page www.gypsumsolutions.com also contains helpful information, including all USG literature.

Prices Subject to Change
Email for exact pricing and availability.

Banding Wheels

Banding Wheels

PLASTIC BANDING WHEEL

This ruggedly constructed turntable is excellent for hand building and decorating. Concentric rings assist in centering your ware for banding. The wheelhead rotates on three ball bearings, precisely placed to maintain smooth, stable turning.

NL261 8" x 1-1/2" \$28.99



CSI TURNTABLES

Heavy duty, very stable banding wheels. "Lazy Susan" type bearing system. Top and bottom are particle board with durable formica cover. Easily cleaned with damp sponge or wet cloth (do not submerge in water). 8" wheel can handle up to 300 lbs. and 12" and 16" wheels can handle up to 500 lbs.

Model	Diameter	Each
TT8	8"	34.99
TT12	12"	39.95
TT16	16"	49.95



LAGUNA BANDING WHEELS

These banding wheels represent excellent workmanship featuring cast iron/aluminum wheels and a ring of steel ball bearings for smooth and easy operation. The concentric circles on the head allow for easy centering. All but the 2" wheels offer high shank for easy use for large hands.

Item#	Diameter	Height	Each
NL273	8-1/2"	2"	84.99
NL275	8-1/2"	5"	69.99
NL274	8-1/2"	6-1/4"	68.95
NL276	10-1/2"	6-1/4"	119.99
NL278	12"	2"	119.99
NL277	12"	6-1/4"	139.99



NIDEC-SHIMPO BANDING WHEELS BW SERIES

These banding wheels feature precise ball bearing rotation. Concentric rings are marked on the wheel head for easy centering. They turn evenly and smoothly. Heavy duty construction and rust resistant finish.

Model	Diameter	Height	Each
BW-18LC	7"	2-1/4"	68.00
BW-22LC	8-3/4"	2-1/4"	82.00
BW-25LC	9-7/8"	2-1/4"	111.00
BW-25HC	9-7/8"	7-1/2"	124.00
BW-30MC	11-3/4"	4-3/4"	146.00



Plaster

Plasters

ClayPeople is the Northern California distributor for USG plasters. For individual product data sheets see www.gypsumsolutions.com, or ask us and we will give you one for free. Contact ClayPeople staff for assistance choosing the right plaster to fit your project.

GENERAL USE PLASTERS

HYDROCAL WHITE

White gypsum cement that can be carved or built-up. It is a good choice for finished pieces such as sculptures, lamp bases and architectural elements. Consistency: 45.

CASTING PLASTER NO. 1

No. 1 Casting Plaster is the industry's premier casting plaster for fabricating figurines, plaques and lamp bases. Chip-resistance and reduced paint absorption, it is stark white in color; smooth-working. Features proprietary additives that minimize paint absorption. Requires 65 parts water by weight per 100 parts plaster. Consistency: 65.

TOOLING & MASTER MOLDS PLASTERS

HYDROCAL B-11

Low expansion and dimensional accuracy. Plasticity for more gradual setting action makes it more suitable for buildup or template-formed models. Consistency: 42.

ULTRACAL 30

Surface hardness and compressive strength are higher and setting expansion is lower than Hydrocal B-11, but has similar workability and setting characteristics. Consistency: 38.

CERAMIC PLASTERS

CERAMICAL

Low consistency gypsum cement. Smooth wearing mold material for use in pressing clay ware. Characterized by low absorption and specified for use with RAM automatic forming equipment. Consistency: 40.

POTTERY PLASTER #1

Highly uniform, noted for outstanding performance and long life. The standard of the industry, it is the best material available for slip casting or jigger molds. Consistency: 70.

STATUARY PLASTERS

HYDROSTONE

Develops the highest compressive strength of any gypsum cement. Strongest and fastest super-strength gypsum cement available. Consistency: 32.

Plaster Pricing

Prices are per 50-pound Bag, price drops per bag as weight increments increase. Combine plasters for volume discounts.

CODE	PRODUCT	50#	100#	500#	1k#	2k#
B11	Hydrocal B-11	47.00	44.15	40.70	37.60	36.05
CER	Ceramical	45.50	42.00	40.00	38.05	35.55
CAS1	Casting Plaster No. 1	25.00	23.70	22.55	21.55	20.50
HS	Hydrostone	43.00	39.80	37.95	35.50	34.50
HYD	Hydrocal, White	42.50	39.65	37.40	35.50	32.00
POT	Pottery Plaster #1	35.00	31.50	29.65	27.75	26.20
UC	Ultracal 30	54.50	48.55	47.15	45.15	42.45

Raw Materials

Prices are per lb. Except when 1/4 or 1/2 pound.

PRODUCT	1/4#	1/2#	1#	5#	10#	25#	50#	100#	500#	1k#	2k#
ALBERTA SLIP CLAY (44#)	X	X	5.26	4.21	3.59	3.15	2.84	2.62	2.31	2.20	2.10
ALUMINA HYDRATE	X	X	5.30	4.22	3.69	3.51	2.98	2.50	2.20	2.11	2.00
ALUMINA OXIDE- CALCINED	X	X	7.43	7.01	6.80	6.60	6.40	5.77	5.24	4.71	4.18
BALL CLAY KENTUCKY OM-4	X	X	2.99	1.65	1.05	0.85	0.52	0.46	0.41	0.39	0.37
BALL CLAY TENN. #1 (SGP #1)	X	X	2.99	1.50	.85	.75	.53	X	X	X	X
BALL CLAY XX SAGGER	X	X	2.99	0.90	0.78	0.67	0.56	0.50	0.44	0.42	0.40
BARIUM CARBONATE,55#BAG)	X	X	6.12	4.88	4.27	3.66	3.29	3.06	2.68	2.44	2.26
BENTONITE, SODIUM 325	X	X	2.99	1.99	1.65	1.43	1.10	0.98	0.87	0.87	0.87
VEE GUM - T "STANDARD"	X	X	19.92	18.99	17.83	16.74	15.73	14.73	X	X	X
BONE ASH	X	X	4.23	2.96	2.63	2.43	2.10	1.89	1.78	1.89	1.58
BORAX-GRANULAR-10 (55lb)	X	X	2.99	2.41	2.30	2.10	1.57	1.35	1.15	1.10	1.04
BORAX, PWD10 MOL (55lb)	X	X	5.41	4.94	3.29	3.04	2.62	2.36	2.22	2.11	1.96
BORIC ACID, GRAN (55lb)	X	X	5.76	4.23	3.75	3.17	X	X	X	X	X
C-1 CLAY SUB #2, DRY CLAY	X	X	1.99	1.09	.88	0.78	0.67	0.62	0.55	0.50	0.44
CALCIUM CARBON. (WHITING)	X	X	2.99	0.99	.56	0.51	.46	X	X	X	X
CHROMIUM GREEN OXIDE	5.99	10.77	19.96	17.95	16.73	15.80	13.64	X	X	X	X
CMC POWDER 7-L (CMC)	8.71	14.41	25.22	23.42	22.82	X	X	X	X	X	X
Cobalt Carbonate	25.41	39.44	73.32	69.09	64.96	X	X	X	X	X	X
Cobalt Oxide	25.12	39.00	72.50	68.32	64.24	X	X	X	X	X	X
CORNWALL STONE-SUB	X	X	5.85	4.45	3.85	3.30	2.97	2.75	2.42	2.31	2.20
CRYOLITE (55lb)	X	X	6.34	5.81	5.27	4.23	4.05	3.87	3.70	3.34	3.17
DEXTRIN #1402 C*DRYSET	X	X	5.50	4.20	3.70	3.15	2.84	X	X	X	X
DOLOMITE	X	X	2.99	0.90	0.80	0.68	0.56	0.50	0.44	0.42	0.40
FELDSPAR CUSTER	X	X	2.99	2.12	1.76	1.52	0.82	0.77	0.70	0.68	0.65
POTASH FELDSPAR-MAHAVIR	X	X	2.99	2.15	1.89	1.76	1.17	1.05	0.93	0.91	0.88
MINSPAR 200 SODA FELDSPAR	X	X	2.99	1.46	1.12	0.89	0.74	0.67	0.55	0.53	0.51
FIRECLAY GOLD ART	X	X	2.99	1.99	1.63	1.42	1.08	0.98	0.86	0.76	0.65
FIRECLAY LINCOLN 60 (50lb)	X	X	1.99	0.50	0.40	0.33	0.26	0.24	0.21	0.20	0.19
FLUORSPAR SUPERFINE (50lb)	X	X	4.99	4.00	3.50	2.99	2.68	2.48	2.19	2.03	1.99
GERSTLEY BORATE	X	X	3.78	3.48	3.33	3.01	2.26	1.96	1.80	1.75	1.66
GROG, MULCOA-47 20X50	X	X	2.99	1.99	1.79	1.66	1.11	0.99	0.88	0.86	0.83
ILMENITE, GRANULAR	X	X	5.50	4.25	3.69	3.15	2.83	2.61	2.31	2.19	2.09
IRON CHROMATE (50lb)	X	X	5.49	4.99	3.69	3.17	2.84	2.63	2.31	2.23	2.10
IRON OXIDE RED NR-4284	X	X	7.45	6.30	6.08	5.76	5.25	4.73	4.52	4.29	4.18
IRON OXIDE SPANISH RED	X	X	3.90	3.12	2.76	2.54	1.99	1.87	1.65	1.50	1.40
IRON OXIDE, BLACK (55lb)	X	X	7.35	6.30	6.09	5.76	5.27	4.72	4.49	4.30	4.18
IRON OXIDE, YELLOW #569	X	X	7.50	6.30	6.10	5.79	5.27	4.72	4.50	4.29	4.17

Raw Materials

Prices are per lb. except when 1/4 or 1/2 pound.

PRODUCT	1/4#	1/2#	1#	5#	10#	25#	50#	100#	500#	1k#	2k#
EPK KAOLIN	X	X	2.99	1.88	1.50	1.24	0.99	0.87	0.74	0.69	0.62
GLOMAX LL CALCINED	X	X	3.28	2.74	2.51	2.18	1.75	1.64	1.42	1.28	1.20
GROLLEG- ENGLISH KAOLIN	X	X	5.39	3.77	3.36	2.71	2.06	2.28	2.01	2.01	1.74
HELMER KAOLIN	X	X	2.99	1.99	1.64	1.30	1.09	0.98	0.87	0.76	0.65
KINGSLEY KAOLIN	X	X	2.99	0.99	.87	.76	0.65	0.60	0.54	0.49	0.38
OPTICAST KAOLIN	X	X	X	X	X	X	0.73	0.66	0.55	0.52	0.50
#6 TILE KAOLIN	X	X	2.99	2.02	1.79	1.67	1.12	1.00	0.89	0.84	0.77
MAGNESIUM CARBONATE	X	X	9.59	8.95	8.45	7.88	7.06	6.84	6.31	5.78	5.25
MAGNETITE, GRANULAR	X	X	2.99	1.95	1.72	1.39	1.07	X	X	X	X
MANGANESE CARBONATE	X	X	11.99	11.20	13.35	10.65	8.05	7.92	7.71	7.51	7.51
MANGANESE DIOXIDE 325	X	X	3.80	3.16	2.91	2.53	2.02	1.90	1.64	1.51	1.39
MOLOCHITE, 120 MESH (55lb)	X	X	5.50	4.39	3.85	3.30	2.98	2.76	2.42	2.32	2.19
MULLITE 200 MESH (100#)	X	X	2.99	2.55	2.45	2.22	1.65	1.44	1.21	1.17	1.11
NEPHELINE SYENITE A-270	X	X	2.99	1.79	1.49	1.29	0.99	0.89	0.79	0.69	0.45
OCHRE, YELLOW #1158	X	X	6.35	5.85	5.28	4.75	4.22	X	X	X	X
PETALITE 200 MESH (55lb)	X	X	6.14	5.48	4.98	4.40	4.07	3.83	3.60	3.29	3.07
POTASSIUM CARBONATE (55lb)	X	X	6.50	5.99	5.30	4.75	4.24	X	X	X	X
PUMICE FFF, NAVAJO BRAND	X	X	2.99	1.96	1.74	1.63	1.09	0.98	0.87	0.82	0.66
P.V. CLAY - LAGUNA BLEND	X	X	2.99	.89	.79	.69	0.55	X	X	X	X
RAVENSCRAG SLIP, DRY CLAY	X	X	4.23	2.96	2.65	2.45	2.11	1.90	1.79	1.70	1.58
SG-1132 NEW BARNARD SUB	X	X	5.26	4.26	3.70	3.17	2.86	2.63	2.35	2.18	2.12
RED ART CLAY	X	X	2.99	1.99	1.50	1.15	.78	X	X	X	X
SAND CALIFORNIA, 30-MESH	X	X	2.99	1.99	1.50	1.00	0.28	0.25	0.23	0.21	0.20
SAND CALIFORNIA 60-MESH	X	X	2.99	1.99	1.50	1.00	0.28	X	X	X	X
SILICA 200 MESH	X	X	2.99	0.90	0.78	0.68	0.55	0.46	0.40	0.38	0.36
SILICA 325 MESH- US SILICA	X	X	2.99	1.99	1.71	1.44	1.24	1.06	0.94	0.81	0.79
SILICON CARBIDE- 60 GRIT	X	X	11.99	10.99	10.49	9.99	X	X	X	X	X
SODA ASH, DENSE	X	X	2.99	2.45	2.35	2.15	1.57	X	X	X	X
SODIUM BICARBONATE	X	X	2.99	2.45	2.35	2.15	1.54	X	X	X	X
SPODUMENE SUB	X	X	7.68	6.50	8.12	4.95	3.99	3.83	X	X	X
STRONTIUM CARBONATE-FINE	X	X	5.50	4.25	3.70	3.18	2.62	X	X	X	X
TALC, PIONEER #2882 (C-98)	X	X	5.98	2.58	1.78	1.70	.117	1.09	1.07	1.04	.99
TITANIUM DIOXIDE (50lb)	X	X	8.55	8.15	8.05	7.40	5.68	X	X	X	X
TRICALCIUM PHOSPHATE-SYN	X	X	9.45	9.15	8.91	8.17	6.01	X	X	X	X

Raw Materials

Prices are per lb. except when 1/4 or 1/2 pound.

PRODUCT	1/4#	1/2#	1#	5#	10#	25#	50#	100#	500#	1k#	2k#
UMBER, BURNT	X	X	7.55	6.30	6.10	5.78	5.50	X	X	X	X
WOLLASTONITE W-30	X	X	2.99	2.05	1.68	1.47	1.25	X	X	X	X
ZINC OXIDE - MAXIMO	X	X	7.55	6.35	6.15	5.79	5.29	X	X	X	X
ZIRCOPAX PLUS - (55lb)	X	X	8.50	7.55	6.99	6.75	6.19	X	X	X	X
LITHIUM CARBONATE, FINE	24.29	41.11	67.27	59.79	54.19	X	X	X	X	X	X
COPPER CARBONATE (50lb)	9.34	13.55	18.69	17.75	16.82	X	X	X	X	X	X
TIN OXIDE (55lb)	29.57	52.91	93.38	87.15	80.93	X	X	X	X	X	X
NICKEL CARBONATE	12.35	15.17	28.37	26.11	22.58	X	X	X	X	X	X
NICKEL OXIDE, 75% BLACK	19.27	25.29	46.98	38.54	36.14	X	X	X	X	X	X
RUTILE CERAMIC, LIGHT	X	X	26.12	23.17	21.13	19.51	13.74	X	X	X	X
RUTILE, GRANULAR	X	X	6.50	5.85	5.40	4.80	4.23	X	X	X	X
COPPER OXIDE RED	16.35	24.64	45.53	42.98	40.78	X	X	X	X	X	X
COPPER OXIDE, BLACK	8.68	15.73	26.03	23.32	19.52	X	X	X	X	X	X
FFCC250	X	X	5.99	5.20	4.65	4.05	3.48	3.23	3.12	2.91	2.63
FFCC263	X	X	7.42	6.70	5.99	5.19	4.47	4.17	4.02	3.75	3.40
FFCC274	X	X	6.32	5.71	5.10	4.41	3.81	3.55	3.43	3.20	2.89
FFCC279	X	X	8.88	8.02	7.17	6.20	5.35	4.98	4.81	4.49	4.06
FFFA233	X	X	8.54	7.71	6.89	5.97	5.14	4.79	4.63	4.32	3.91
FFFB276P	X	X	8.64	7.80	6.97	6.04	5.20	4.85	4.68	4.37	3.95
FFFB284M	X	X	6.87	6.21	5.54	4.80	4.14	3.86	3.72	3.48	3.14
FF3110	X	X	5.65	5.03	4.46	3.90	3.34	3.18	3.06	2.87	2.56
FF3124	X	X	4.69	4.15	4.00	3.38	3.02	2.76	2.62	2.50	2.34
FF3134	X	X	5.71	5.10	4.58	4.11	3.40	3.14	3.00	2.80	2.55
FF3195	X	X	6.50	5.45	4.95	4.45	4.15	3.92	3.68	3.35	3.12
FF3249	X	X	10.05	9.54	12.03	9.02	7.82	7.62	7.26	7.02	6.74
FF3264	X	X	6.25	5.68	5.24	4.54	4.19	4.02	3.84	3.42	3.23

Colorant Information

CHROME OXIDE - Cr_2O_3 is used (in small amounts $<2\%$; it is very refractory) to produce greens. This Oxide has a chameleon-like effect on glazes depending on the choice of temperature and flux source, i.e. KNaO , CaO BaO , or MgO . Used with Tin, it produces pink, but with Zinc Oxide it produces brown.

COBALT CARBONATE - CoCO_3 is used to produce blues in glazes. It is sometimes preferred over the Oxide form due to its particle size, thus eliminating ball milling. Cobalt Oxide can substitute for the Carbonate form if used in one-half the given amount. Can also be used with Manganese, Iron Chromate, or Nickel to produce strong blacks.

COBALT OXIDE - Co_3O_4 is the major oxide used for producing blues. It gives comparable tints of blue in almost all firing ranges and varying firing methods. It's a very strong colorant (typically $<2\%$ is used). Glazes employing it as a colorant should be ball milled if mottling is not desired. When using Cobalt Carbonate the amount should be doubled.

COPPER CARBONATE - CuCO_3 is the most common source for Copper Oxide and is used (2%-5%) as a major colorant to produce greens, turquoise, and copper reds. Carbonate form is preferred over the oxide due to finer particle size, which enhances production Alkaline glazes: turquoise in oxidation, and copper red in reduction. Volatile above cone 8 and may require a sagger to protect other ware and kiln.

COPPER OXIDE BLACK - (CuO) **RED** (Cu_2O) are the two stable forms of Copper Oxide. Both forms are coarser in particle size than Copper Carbonate. The more common of the two forms (in a glaze) is copper black (2%-5%). It is a strong flux used as a colorant to produce greens in oxidation and reds in reduction. Red Copper Oxide can be precipitated during reduction firings as a component of a copper red glaze finish. Other colors are turquoise in Soda based glazes, yellow-greens in Potash, and blue-greens in Barium. Copper Carbonate can be substituted for Oxide if the amount is doubled.

IRON OXIDE - **Red:** Fe_2O_3 Iron Oxide is the most commonly used form of Iron as a colorant in glazes and clay bodies. Used most often to produce brown colors. In amounts greater than 4% it can react as a flux, increasing fluidity of the glaze. **Black:** FeO Iron Oxide as a colorant will create a variety of colors depending on the glaze base used. Effect is often the same as Red Iron Oxide. However, it is preferred for producing celadon glazes in reduction firing. **Yellow #5060** - is a manufactured product that can be relied on to produce consistent results.

MANGANESE DIOXIDE - MnO_2 is a source of MnO in glazes or clay bodies, and is used to develop reds, blues, purples, and black (MnCO_3 is a weaker colorant per unit weight of MnO than MnO_2 , at a minimum, twice the amount is needed). It is a vigorous flux (cone 5-10) in glaze and clay bodies (in a clay body use $<5\%$), and a strong oxidizing agent in glazes. Powder and granular forms differ by particle size and reactivity. Granular form can be used at higher temperatures where the reduced reactivity will develop dark speckles in both clay bodies and glazes.

NICKEL OXIDE - **Green:** NiO Green Nickel Oxide (typically $<3\%$) is used in glazes (most commonly porcelain enamels) to produce blues, greys, browns, and yellows, depending on molecular equivalence of the Alkaline earths chosen. It can also be used to soften the effect of Cobalt and Copper colorants. **Black:** Ni_2O_3 in a glaze Black Nickel Oxide will reduce to Green Nickel Oxide at 600o C and produces similar results as NiO . Greater amounts may need to be added to a glaze to achieve the same effects.

RUTILE - TiO_2 is an economical source of TiO_2 when pure white is not required. Used in clay bodies and glazes (typically 1-3%) to produce ivory to yellow to dark tans in oxidation, and purples and blues in reduction. Used to modify action of other colorants and to produce special effects like mottling and streaking especially in Gerstley Borate/ Colemanite glazes. Light Ceramic is a fine size true Rutile with some Iron contamination. Granular is a coarse particle size true Rutile with some Iron contamination. The granular form is less reactive than the Light Ceramic grade and therefore, is used to promote mottling at higher temperatures (cone 8-13).

SILICON CARBIDE BLACK - SiC contains up to 10% Free Silica and is highly refractory. It is used mainly in high temperature kiln furniture (cones 5-16), and has been experimented with in Alkaline glazes in amounts of 0.5 to 1.0% to produce artificial copper reds.

Mason Stains®

Blues

Mason Stains® (by Mason Color Works) is one of the leading stain manufacturers in the United States. We carry the complete Mason color line.

Use them to color to glazes, slips and clay bodies. Most Mason stains® can be used at any temperature.

#	Color	1 oz.	1/4#	1/2#	1#
6300	Mazerine Blue	5.63	15.32	24.90	45.96
6302	Cadet Blue	5.30	14.44	23.47	43.32
6305	Teal Blue	3.36	9.16	14.89	27.48
6306	Vivid Blue	3.20	8.72	14.17	26.16
6307	Pastel Blue	2.03	5.52	8.97	16.56
6308	Delphinium Blue	3.89	10.60	17.23	31.80
6310	Wedgewood Blue	4.77	13.00	21.13	39.00
6313	Medium Blue	4.27	11.64	18.92	34.92
6315	Zr Vn Blue	3.14	8.56	13.91	25.68
6320	Delft Blue	6.58	17.92	29.12	53.76
6330	Cobalt Aluminate	6.90	18.80	30.55	56.40
6336	Peacock Blue	5.90	16.08	26.13	48.24
6338	Cobalt Meta Sili-	7.55	20.56	33.41	61.68
6339	Royal Blue	3.88	10.56	17.16	31.68
6343	Mediterranean	3.61	9.84	15.99	29.52
6350	Bright Blue	3.28	8.92	14.50	26.76
6360	Willow Blue	5.74	15.64	25.42	46.92
6363	Sky Blue	2.23	6.08	9.88	18.24
6364	Turquoise Blue	3.17	8.64	14.04	25.92
6368	Copen Blue	2.25	6.12	9.95	18.36
6371	Dark Teal Blue	4.95	13.48	21.91	40.44
6373	Turquoise Blue	3.61	9.84	15.99	29.52
6374	Dark Turquoise	3.33	9.08	14.76	27.24
6376	Robin's Egg Blue	3.07	8.36	13.59	25.08
6378	Zr Vn Blue	3.33	9.08	14.76	27.24
6383	Cobalt Aluminate	5.79	15.76	25.61	47.28
6386	Navy Blue	5.45	14.84	24.12	44.52
6388	Mazerine Blue	6.27	17.08	27.76	51.24
6389	Sapphire Blue	5.92	16.12	26.20	48.36
6391	Zr Vn Blue	3.17	8.64	14.04	25.92
6393	Turquoise Blue	3.85	10.48	17.03	31.44
6396	Peacock Blue	3.44	9.36	15.21	28.08
6398	Deep Peacock	5.79	15.76	25.61	47.28

#	Color	1 oz.	1/4#	1/2#	1#
6303	Deep Orchid	4.42	12.04	19.57	36.12
6304	Cr Tin Violet	9.81	26.72	43.42	80.16
6317	Lavender	4.26	11.60	18.85	34.80
6318	Amethyst	4.33	11.80	19.18	35.40
6319	Lavender	2.36	6.44	10.47	19.32
6324	Violet	4.02	10.96	17.81	32.88
6331	Orchid	4.47	12.16	19.76	36.48
6332	Orchid	4.35	11.84	19.24	35.52
6333	Lavender	4.35	11.84	19.24	35.52
6381	Blackberry Wine	4.66	12.68	20.61	38.04
6385	Pansy Purple	4.88	13.28	21.58	39.84
6387	Mulberry	4.88	13.28	21.58	39.84
6392	Dusty Lavender	3.83	10.44	16.97	31.32
6591	Gun-Metal	2.88	7.84	12.74	23.52

Purples

Blacks

#	Color	1 oz.	1/4#	1/2#	1#
6600	Black	3.77	10.28	16.71	30.84
6601	Velvet Black	4.20	11.44	18.59	34.32
6609	Black	3.88	10.56	17.16	31.68
6612	Onyx	5.82	15.84	25.74	47.52
6616	Chrome-free Black	4.85	13.20	21.45	39.60
6650	Cobalt-free Black	2.57	7.00	11.38	21.00
6657	Black	2.64	7.20	11.70	21.60
6666	Cobalt-free Black	2.76	7.52	12.22	22.56

Mason Stains®

Pink, Red, & Corals



#	Color	1 oz.	1/4#	1/2#	1#
6000	Shell Pink	4.64	12.64	20.54	37.92
6001	Alpine Rose	4.61	12.56	20.41	37.68
6002	Rose Pink	4.66	12.68	20.61	38.04
6003	Crimson	4.69	12.76	20.74	38.28
6004	Crimson	4.70	12.8	20.80	38.40
6005	Deep Crimson	4.70	12.8	20.80	38.40
6006	Deep Crimson	4.76	12.96	21.06	38.88
6007	Peach	5.41	14.72	23.92	44.16
6008	Peach	5.21	14.2	23.08	42.60
6009	Coral	4.63	12.6	20.48	37.80
6020	Mn Alum. Pink	2.19	5.96	9.69	17.88
6022	Shrimp Pink	4.71	12.84	20.87	38.52
6023	Clover pink	4.16	11.32	18.40	33.96
6024	Orange	4.19	11.4	18.53	34.20
6025	Coral Red	5.38	14.64	23.79	43.92
6026	Lobster	4.45	12.12	19.70	36.36
6027	Tangerine	4.45	12.12	19.70	36.36
6028	Orange	7.05	19.2	31.20	57.60
6029	Persimmon	1.98	5.4	8.78	16.20
6030	Mango	7.05	19.2	31.20	57.60
6031	Deep Salmon	4.08	11.12	18.07	33.36
6032	Zr Fe Coral	2.92	7.96	12.94	23.88
6033	Sunset	5.08	13.84	22.49	41.52
6052	Doll Flesh	2.20	6	9.75	18.00
6065	Cr Alumina Pink	2.19	5.96	9.69	17.88
6067	Pink Extender	4.66	12.68	20.61	38.04
6069	Dark Coral	4.51	12.28	19.96	36.84
6090	Coral	5.43	14.8	24.05	44.40
6098	Flesh	4.04	11	17.88	33.00
6021	Red	7.27	19.8	32.18	59.40
6088	Dark Red	7.27	19.8	32.18	59.40
6097	Red	7.04	19.16	31.14	57.48

Brown & Orange

Mason Stains® (by Mason Color Works) is one of the leading stain manufacturers in the United States. We carry the complete Mason color line.

Use them to color to glazes, slips and clay bodies. Most Mason stains® can be used at any temperature.

#	Color	1 oz.	1/4#	1/2#	1#
6100	Woodland Brown	2.25	6.12	9.95	18.36
6101	Chestnut Brown	2.23	6.08	9.88	18.24
6103	Golden Brown	2.25	6.12	9.95	18.36
6104	Fawn	4.47	12.16	19.76	36.48
6107	Dark Golden	2.26	6.16	10.01	18.48
6108	Walnut Brown	2.31	6.28	10.21	18.84
6109	Deep Brown	2.45	6.68	10.86	20.04
6110	Violet of Iron	1.94	5.28	8.58	15.84
6111	Spice Brown	3.94	10.72	17.42	32.16
6113	Claret Brown	1.69	4.60	7.48	13.80
6119	Russet Brown	1.82	4.96	8.06	14.88
6121	Saturn Orange	2.25	6.12	9.95	18.36
6122	Cedar Brown	2.32	6.32	10.27	18.96
6123	Saddle Brown	2.32	6.32	10.27	18.96
6124	Chocolate Brown	2.31	6.28	10.21	18.84
6125	Leather Brown	2.28	6.20	10.08	18.60
6126	Hazelnut Brown	2.38	6.48	10.53	19.44
6129	Golden Ambrosia	2.22	6.04	9.82	18.12
6131	Ti Iron Brown	2.12	5.76	9.36	17.28
6132	Red Brown	2.25	6.12	9.95	18.36
6133	Sorrel Brown	2.29	6.24	10.14	18.72
6134	Red Brown	2.34	6.36	10.34	19.08
6149	Iron Silicate	1.81	4.92	8.00	14.76
6153	Seal Brown	1.66	4.52	7.35	13.56
6155	Black Brown	2.31	6.28	10.21	18.84
6160	Dark Chocolate	1.78	4.84	7.87	14.52
6163	Terra Cotta	2.25	6.12	9.95	18.36
6166	Camel Beige	2.29	6.24	10.14	18.72
6181	Sandstone	1.48	4.04	6.57	12.12
6190	Deep Brown	1.63	4.44	7.22	13.32
6194	Mn Silicate	1.57	4.28	6.96	12.84

Mason Stains®

Greens

Mason Stains® (by Mason Color Works) is one of the leading stain manufacturers in the United States. We carry the complete Mason color line.

Use them to color to glazes, slips and clay bodies. Most Mason stains® can be used at any temperature.

#	Color	1 oz.	1/4#	1/2#	1#
6200	Evergreen	2.29	6.24	10.14	18.72
6201	Celadon Green	2.20	6.00	9.75	18.00
6202	Florentine Green	3.16	8.60	13.98	25.80
6204	Victoria Green	2.16	5.88	9.56	17.64
6206	Grass Green	2.13	5.80	9.43	17.40
6207	Celeste Green	2.26	6.16	10.01	18.48
6209	Chrome Green	3.13	8.52	13.85	25.56
6211	Pea Green	3.82	10.40	16.90	31.20
6213	Hemlock	2.86	7.80	12.68	23.40
6219	French Green	2.38	6.48	10.53	19.44
6221	Turquoise Green	2.01	5.48	8.91	16.44
6223	Ivy Green	2.61	7.12	11.57	21.36
6224	Dark Green	2.20	6.00	9.75	18.00
6226	Dark Leaf Green	1.97	5.36	8.71	16.08
6234	Myrtle Green	4.95	13.48	21.91	40.44
6236	Chartreuse	5.41	14.72	23.92	44.16
6242	Bermuda Green	3.28	8.92	14.50	26.76
6244	Deep Sea Green	4.29	11.68	18.98	35.04
6246	Blue Green	3.45	9.40	15.28	28.20
6254	Dark Teal Green	4.32	11.76	19.11	35.28
6255	Jade Green	3.98	10.84	17.62	32.52
6263	Victoria Green	2.22	6.04	9.82	18.12
6264	Victoria Green	2.19	5.96	9.69	17.88
6265	Leaf Green	2.23	6.08	9.88	18.24
6266	Peacock Green	5.57	15.16	24.64	45.48
6267	Emerald Green	2.51	6.84	11.12	20.52
6268	Sea Green	3.07	8.36	13.59	25.08
6271	Mint Green	2.19	5.96	9.69	17.88
6274	Nickel Silicate	2.92	7.96	12.94	23.88
6280	Avocado	4.32	11.76	19.11	35.28
6288	Turquoise Green	2.69	7.32	11.90	21.96
6296	Dark Spruce Green	3.61	9.84	15.99	29.52

#	Color	1 oz.	1/4#	1/2#	1#
6404	Vanadium Yellow	6.99	19.04	30.94	57.12
6405	Naples Yellow	2.56	6.96	11.31	20.88
6406	Buttercup Yellow	3.80	10.36	16.84	31.08
6407	Marigold	3.17	8.64	14.04	25.92
6410	Canary Yellow	4.23	11.52	18.72	34.56
6434	Yellow Oxide	2.14	5.84	9.49	17.52
6440	Vanadium Yellow	7.11	19.36	31.46	58.08
6450	Praseodymium Yellow	3.53	9.60	15.60	28.80
6464	Zirconium Yellow	4.55	12.40	20.15	37.20
6471	Old Gold	5.04	13.72	22.30	41.16
6479	Sunshine	6.59	17.96	29.19	53.88
6485	Titanium Yellow	2.38	6.48	10.53	19.44

Yellows

#	Color	1 oz.	1/4#	1/2#	1#
6500	Sage Grey	3.16	8.60	13.98	25.80
6503	Taupe Grey	1.72	4.68	7.61	14.04
6506	Pearl Grey	5.57	15.16	24.64	45.48
6515	Soft Med. Grey	1.72	4.68	7.61	14.04
6523	Soft Green Grey	1.78	4.84	7.87	14.52
6527	Shadow Grey	1.89	5.16	8.39	15.48
6528	Charcoal Grey	6.39	17.40	28.28	52.20
6530	Silver Grey	7.06	19.24	31.27	57.72
6531	Slate Grey	3.36	9.16	14.89	27.48
6537	Mouse Grey	2.04	5.56	9.04	16.68
6540	Blue Grey	5.68	15.48	25.16	46.44
6572	Neutral Grey	1.75	4.76	7.74	14.28
6573	Rose Taupe	2.88	7.84	12.74	23.52
6591	Gun-Metal	3.32	9.04	14.69	27.12

Grays

#	Color	1 oz.	1/4#	1/2#	1#
6700	White	1.72	4.68	7.61	14.04
6768	Tin White	7.21	19.64	31.92	58.92
6790	White for Mat-	1.76	4.80	7.80	14.40

Whites

Potter's Wheels

Nidec-Shimpo Whisper Wheels

Most Wheels
20% Off
15% Off Lites

NIDEC-SHIMPO VL WHISPER

The quietest potter's wheel on the market. Responsive, high torque at all speeds, and powerful. Comes equipped with a 1/2 HP motor, a 14" wheelhead allowing you to center up to 100 lbs. Features a reversing switch, a remote foot pedal, and adjustable height to accommodate all throwing positions. Comes with a free splash pan and a five-year warranty. **SVLWSPR** List \$1750 - **20% OFF \$1400**



NIDEC-SHIMPO RK WHISPER

Responsive, high torque at all speeds, powerful and quiet. Comes equipped with a 1/2 HP motor, a 12" wheelhead allowing you to center up to 100 lbs. Features a reversing switch, a fixed foot pedal and hand lever. Accommodates left and right hand users. Comes with a free splash pan and a five-year warranty. Special Order. **SRKWSPR** List \$1600- **20% OFF \$1280**



NIDEC-SHIMPO VL-LITE

A Truly En "Lite" tening Potter's Wheel! Designed with the potter in mind, the VL-Lite is a belt-driven lightweight wheel. "Lite" enough to carry yet sturdy enough to throw on. Featuring a remote pedal, two-piece splash pan, workspace, 100-watt reversible motor, an automatic belt-tensioning system and a "Lite" price. **SVLLITE** List \$975- **15% OFF \$828.50**

NIDEC-SHIMPO WORK TABLE ATTACHMENTS

SWORKTL	Large	\$119.00
SWORKTS	Small	\$109.00

2-PIECE SPLASH PAN

AC-001-2VL-A 2-pc splash pan, snap with flaps **\$75.00**



Skutt Wheels

- PRODIGY
- LEGEND
- REVOLUTION
- PREMIER

EMAIL FOR PRICES



Lockerbie Kickwheel

Combines the durability and toughness of old-fashioned kickwheels with the style, performance and engineering demanded by today's potters. Heavy gauge steel frame provides a solid, stable base. A tapered roller bearing under the flywheel keeps the wheel spinning smoother and longer. Rated for 1,000 pounds of weight. 4 sq. ft. worktable and seat are ergonomically designed to maximize work area while providing comfortable knee clearance. Seat can be adjusted or reversed for longer or shorter legs. Splash pan included. 30 Day Total Satisfaction Guaranteed. Special Order.

KICKWHEEL / MOTORIZED KICKWHEEL
EMAIL FOR PRICES



Potter's Wheels

Pacifica Wheels

PACIFICA MODEL GT400 & GT800

Equipped with a welded steel frame, 13" machined aluminum wheel head, durable molded table and easy to remove splash pan. The quiet, high torque "Magic pedal" is equally smooth at low speeds and is reversible. Splash pan included. Comes with two year warranty. Pacifica wheel accessories are listed on page 60.

GT400 - Delivers 1/2 HP, centers 80 lbs.
List \$1259.50 - **20% OFF \$1007.60**

GT800 - Delivers 1 HP, centers 100 lbs.
List \$1485 - **20% OFF \$1188**
Pacifica Belt 42" or 50" - \$19.99



SEAT OPTIONAL
\$134

Most Wheels
20% Off
15% off Lites



Lisa
Customer Service
Manager

There are many things to consider when buying a wheel. These include motor size, work space area, splash pan, wheel noise, durability, and cost.

We will help you find the wheel that is the best value for you. Also, you can "test drive" wheels at ClayPeople.

Brent Wheels



MODEL EX/CXC/C/B
(models have similar appearance)

All Brent wheels have sensitive electronic foot pedal controls, smooth-running permanent magnet D.C. motors, reversing switches, and all-steel construction. Brent's electric wheels are very sturdy and dependable. Wheels come with a ten-year warranty, except the IE, which has a five-year warranty.

MODEL EX

The most powerful Brent wheel available. The heavy-duty 1-1/2 hp motor has the power to center over 100 lbs. of clay! The 14" cast aluminum wheel head can handle virtually any throwing project up to 450 lbs. of clay. Special Order.
Email for pricing.

MODEL CXC

A longtime best seller. Comes equipped with a 1 HP motor, 14" cast aluminum wheel head, and can center up to 300 lbs. of clay.
List \$2550 - **20% OFF \$2040**

MODEL B

Excellent for schools and studios. Comes with 1/2 HP motor, 12" cast aluminum wheel head, splash pan, and can center up to 150 lbs. of clay. Splash pan included.
List \$2350 - **20% OFF \$1880**

MODEL C

A workhorse wheel. Equipped with a 3/4 HP motor, 14" cast aluminum wheel head, and can center up to 225 lbs. of clay.
List \$2450 - **20% OFF \$1960**

Prices Subject to Change
Email for exact pricing.

Wheel Accessories

Most Wheels
20% Off
15% Off Lites



Kiln Discounts

Wyatt

General Manager

We sell most kilns at 10% off list price.

We can special order any kiln not featured in our catalog.

Call today for details and availability.

STUDIO PRO PLASTIC BATS

Throwing bats made by potters for potters using CNC routers for dimensional accuracy and hole spacing. Long lasting, rigid, high-impact plastic. Calibrated for standard wheels.

BATSP7	8"	\$8.85
BATSP9	Square 9"	\$9.10
BATSP12	12"	\$13.50
BATSP14	14"	\$18.50
BATSP16	16"	\$30.50
BATSP18	18"	\$34.25
BATSP22	22"	\$65.99

STUDIO PRO MASONITE BATS

Calibrated for Brent, Pacifica, Nidec-Shimpo Master and Lockerbie wheels. Precision cut on CNC router dies.

BATM9	Square 9"	\$5.25
BATM12	12"	\$5.50
BATM14	14"	\$7.40
BATM15	15"	\$8.45

STUDIO PRO MEDEX BATS

Wood product without formaldehyde, 3/8" thick. Handles like masonite. Waterproof, no warping, strong & long lasting.

BATMED12	12"	\$6.99
BATMED14	14"	\$8.99
BATMED16	16"	\$11.99
BATMED18	18"	\$15.99
BATMED1222"		\$21.99



LAGUNA PLASTER BATS

Made from top quality plaster for a combination of good water absorption and wear resistance. Will stick to wheel head without bat pins.

BATPL8	\$10.82	BATPL12	\$14.99
BATPL10	\$12.99	BATPL14	\$16.99

SELF ADHESIVE FOAM

Peel-and-stick self-adhesive foam trimming bat is ideal for trimming large bowls and plates without the use of a coil to attach the piece to the wheel head. **XXASF \$10.99**



BAT MATE

Place Batmate™ below your problem bats on the wheel and instantly your warped bats become stable.

XXBM12	12"	\$9.95
XXBM14	14"	\$10.95

Bats

SPEEDBALL PLASTIC BATS

These bats are made out of injection molded plastic. They can't warp, the pin holes can't enlarge, and they will never wear out. Unique design allows bat to fit any bat pin configuration.



SBGB	7-1/2" Square	\$8.99
BB12	12" Diameter, Blue	\$11.99
OB14	14" Diam. Brn/Orange	\$14.99

STUDIO PRO ADAPTER BAT SYSTEM

A system for making smaller pots and maximizing space in your studio. Compatible with the now unavailable Wonderbat. Set comes with a 14" adapter bat and 8- 6" inserts. Made from 1/2" exterior grade MDF which provides excellent bottom drying and rigidity. The adapter bat mounts on standard wheel-head pins with rubber "through hole" grommets making a true two-sided bat.



SPASAVADP	14" Bat	\$40.99
SPASAVSET	Bat with/8 Inserts	\$73.99
SPBATINSERT	6" Insert	\$5.50

GRINDING DISKS

12" diameter silicon carbide grinding disks with peel-off adhesive backing. Attach to a 12" bat and grind at the highest wheel speed. The 50 grit takes of material fastest, while the 80 grit gives the smoothest finish.

GRINDD80	80 Grit	\$9.95/each
GRINDD50	50 Grit	\$9.95/each

GIFFIN GRIPS

A re-centering, holding tool for leather hard or bisque. Designed for trimming, waxing or banding. Includes basic and wider sets.

	2", 4" & 6" arms.	
GG		\$249.00
GGMINI		\$199.00



Wheel Accessories

Wheel Leg Extensions

BRENT LEG EXTENSION KIT

Raise your wheel to standing height to reduce stress on your back. This leg extension kit fits wheels B, C, or CXC and adjusts the wheel head height from 31 1/2 inches up to 42 inches high. **\$249**



PACIFICA WHEEL LEG EXTENSIONS

Two optional leg extensions increase the versatility of the Pacifica wheel, adding up to 10" (Extension A) or 23" for stand up throwing (Extension B) to the height of the wheel.

Extension A \$71.50

Extension B \$159.50

PACIFICA WORKSTATION

Triplies work space to over 7 square feet. Puts tools and pots at your fingertips. Installs in less than 5 minutes.

Fits Pacifica wheels, Nidec-Shimpo V35, V75 and VL Whispers, Brent B, C, CXC, EX.

PWWS \$209



Potter's Stools

NIDEC-SHIMPO POTTER'S STOOL

Cushion Seat. Adjustable legs allow for tilted seating. Adjustable, 18" to 25" tall.

SPSA \$94.00



BRENT SPLASH PAN

Fits all Brent models. Available in yellow.

BSPL \$70.00

SHIMPO SPLASH PAN

Fits all Shimpo models. Available in white.

SSP \$71.00



PACIFICA POTTER'S SEAT

A solid, comfortable and adjustable, padded seat that will allow you to throw for hours on end.

The seat easily mounts onto the leg of your Pacifica wheel, and large grip knobs make for easy adjustment.

PWSEAT \$237

PACIFICA SPLASH PAN

Fits all Pacifica models.

PWSP \$82.50



CLAYPEOPLE BUCKETS

The perfect size mixing pail. Holds 4 quarts of liquid. Plastic reinforced lip adds body strength. Metal handle increases usability.

BUCKET \$2.99

CLAYPEOPLE BUCKET LIDS!

Made to fit the ClayPeople buckets! **LIDS \$2.99**

BAT PINS

Fits all bats pair

BATP \$3.95



Prices Subject to Change

Email for exact pricing.

Kilns

Test and Small Kilns

AIM 88 3-KEY

Test kiln with Bartlett 3-Key Automatic Controller and stand. Fires to cone 10. 120 volts, 15 Amps. 8" x 8" x 9" deep. AIM883KEY Our Price \$1095



SKUTT GLAZETECH

Perfect for firing small sets of tiles and perfecting your glaze, with 3-key controller to store programs for repeated firing. Fires to cone 10. 240 volts, 200 Amps. 14.5" x 9"

KMGlazetech 208V & 240V 1Ph
KMGT2401 \$2039
 Our Price \$1835.10
KMGT2081 \$1725.00
 Our Price \$152.50



SKUTT KM FIREBOX LT

Perfect for glaze testing, enameling and other small low fire ceramic projects. 115 volts, 15 Amps. 8" x 8" x 6" deep. Fires to cone 6.

KM Firebox LT 8x4
 List Price \$1215 Our Price \$1093.50
KM Firebox LT 8x 6
 List Price \$1290 Our Price \$1161



SKUTT KM 614-3

Economical test kiln with precision control. One of the largest operating on 120 volts. Constructed with 3" brick which increases insulation for a more efficient firing. Comes with a Skutt Kiln Master controller for automatic electronically controlled firing. The KM 614-3 additionally is the only kiln in the Skutt KM series that can be fired on a common household 115V current using a special 30 amp outlet. Fires to cone 6. 11" wide, 13-1/2" deep. 0.8 cubic feet.

KM-614-3 115V 1Ph List Price \$2057- Our Price \$1851.30

SKUTT KM 818 and 818-3

This small octagonal kiln has been revered as the work-horse of the small studio. This kiln comes with either 3" (KM 818-3) or 2-1/2" brick. Thicker brick provides more insulation for a more energy efficient firing. The KM 818 comes equipped with a Skutt Kiln Master controller for automatic electronically controlled firing.

Fires to cone 10. 17-1/2" wide, 18" deep. 2.6 cu. ft.
KM-818 208V & 240V 1Ph List Price \$2605- Our Price \$2344.50
KM-818-3 208V & 240V 1Ph List Price \$2717 - Our Price \$2445.30



Medium Kilns

SKUTT KM 714

This is great kiln for beginners or studios firing small loads. It also makes an excellent test kiln. The firing chamber is slightly over 14", which allows you to fire most plates and small platters. The KM 714 comes equipped with a Skutt Kiln Master controller for automatic electronically controlled firing. Fires to cone 8. 14-3/8" wide, 13-1/2" deep. 1.4 cu. ft. Requires a 4-prong receptacle.

KM-714, 208V & 240V 1Ph List Price \$2185- Our Price \$1966.50



Medium Kilns

SKUTT KM 822 and SKUTT KM 822-3

The compact and versatile KM822 is the perfect blend of a home studio model and a great production studio kiln. Requires a 50 amp breaker. Fires to cone 10. 17-1/5" wide, 22" deep. 3.2 cubic feet. KM 822-3 has a 3" fire brick upgrade. 15-1/5" wide, 22" deep. 2.9 cubic feet. Requires a 50 amp breaker.

KM-822 208V & 240V 1Ph List Price \$2814 - **Our Price \$2532.60**

KM-822-3 208V & 240V 1Ph List Price \$2956 - **Our Price \$2660.40**



SKUTT KM 1018 and 1018-3

Offers the wide capacity of a large kiln coupled with the easy loading height of a smaller kiln. Great for large platters and for firing heavy stoneware pieces that are difficult to lift out of deeper kilns. This kiln comes with either 3" (KM 1018-3) or 2-1/2" brick. Thicker brick provides more insulation for a more energy efficient firing. The KM 1018 comes equipped with a Skutt Kiln Master controller for automatic electronically controlled firing. Fires to cone 10. 23-3/8" wide, 18" deep. 4.6 cubic feet.

KM-1018 208V & 240V 1Ph List Price \$3654 - **Our Price \$3288.60**

KM-1018-3 208V & 208V 1Ph List Price \$3784 - **Our Price \$3405.60**

SKUTT KM 1022 and 1022-3

The size of this kiln makes it convenient for many locations while not compromising firing performance. It offers the wide capacity of a large kiln coupled with the easy loading height of a smaller kiln: great for platters! Requires a 60 amp breaker. Fires to cone 10. 23.38" wide, 22" deep. 5.7 cubic feet. KM 1022-3 has a 3" fire brick upgrade. 22.38" wide, 22" deep. 5.25 cubic feet.

KM-1022 208V & 240V 1Ph List Price \$4056 - **Our Price \$3650.40**

KM-1022 208V & 240V 3Ph List Price \$4146 - **Our Price \$3731.40**

KM-1022-3 208V & 240V 1Ph List Price \$4268 - **Our Price \$3841.20**

KM-1022-3 208V & 240V 3Ph List Price \$4358 - **Our Price \$3922.20**

SKUTT TOUCHPAD INFORMATION

Upgrade your digital Skutt to the latest technology! The KMT Upgrade Kit allows you to upgrade your existing KM "Touchpad" with the new KMT Controller giving you a Touchscreen Interface that is much like your Smartphone. It has built in WiFi which allows you to upgrade the firmware. Its a new controller for the life of your kiln. Comes with a free App that allows you to monitor your kiln from wherever you are.

KMTUPGRADE \$410 Additional fee for any KM kiln



Large Kilns

Prices Subject to Change

Email for exact pricing.

SKUTT KM 1027

With its cone 10 power and 7 cubic foot chamber capacity, there are very few projects this kiln can't accomplish. A great kiln for those who fire porcelain and stoneware. This kiln comes with either 3" (KM 1027-3) or 2-1/2" brick. Thicker brick provides more insulation for a more energy efficient firing. The KM 1027 comes equipped with a Skutt Kiln Master controller for automatic electronically controlled firing. Fires to cone 10. 23-3/8" wide, 27" deep. 7.0 cubic feet.

KM-1027 208V & 240V 1Ph List Price \$4435 - **Our Price \$3991.50**

KM-1027-240V 3Ph List Price \$4525 - **Our Price \$4072.50**

KM-1027-3 208V & 240V 1Ph List Price \$4525 - **Our Price \$4122**

KM-1027-3 208V & 240V 3Ph List Price \$4690 - **Our Price \$4221**



Kilns

Large Kilns

SKUTT KM 1218-3

The newest addition to the Skutt line. 6.6 cubic feet of Cone 10 power. Large 28 inch diameter allows for large platters. Low profile design equals easy loading and unloading. Comes with 3" brick standard for better insulation and energy efficiency. This kiln comes equipped with a Skutt Kiln Master controller for automatic electronically controlled firing. Fires to cone 10. 28-1/8" wide, 18" deep. 6.6 cubic feet.

KM 1218-3, 208V & 240V 1Ph List Price \$4612 - **Our Price \$4150.80**
KM 1218-3, 208V & 240V 3Ph List Price \$4967 - **Our Price \$4470.30**

SKUTT KM 1222-3

This 8.1 cubic foot chamber makes the KM 1222-3 popular with schools, modern studios and production companies. Come standard with lid lifter and 3-inch brick. Fires to cone 10. 28-1/8" wide, 27" deep. Requires a 60 amp breaker.

KM 1222-3, 208V & 240V 1Ph List Price \$4877 - **Our Price \$4389.30**
KM 1222-3, 208V & 240V 3Ph List Price \$4967 - **Our Price \$4470.30**

SKUTT KS/KM-1227-3

Designed specifically to meet the intense demands of high volume production. Excellent kiln for potters, sculptors, tile makers, schools and slip casters. Comes with 3" brick standard for better insulation and energy efficiency. The KS 1227-3 comes with a Dawson Kiln Sitter with 20 hour timer for manual firing. The KM 1227-3 comes equipped with a Skutt Kiln Master controller for automatic electronically controlled firing. Fires to cone 6. 28-1/8" wide, 27" deep. 9.9 cubic feet.

KM 1227-3, 208V & 240V 1Ph List Price \$5345 - **Our Price \$4810.50**
KM 1227-3, 208V & 240V 3Ph List Price \$5435 - **Our Price \$4891.50**

Skutt Production Kilns

SKUTT KM 1227-3 PK

Designed with high volume production in mind. It has the power and the industrial components to go straight to cone 10 with a full load of stoneware. Comes with 3" brick standard for better insulation and energy efficiency. Comes with a Skutt Kiln Master controller for automatic electronically controlled firing. Same price for 1- or 3-Phase. Fires to cone 10. 28-1/8" wide, 27" deep. 9.9 cubic feet.

KM 1227-3 PK, 208V & 240V List Price \$6178 - **Our Price \$5560.20**

SKUTT KM 1231-3 PK

The largest cone 10 electric kiln in its class. The combination of direct wiring, heavy duty elements, connectors and relays, plus traditional Skutt stainless steel and firebrick construction results in a kiln that will last for years of constant use. Comes with 3" brick standard for better insulation and energy efficiency. Comes with a Skutt Kiln Master controller for automatic electronically controlled firing. Same price for 1- or 3-Phase. Fires to cone 10. 28-1/8" wide, 31" deep. 11.6 cubic feet.

KM 1231-3 PK, 208V & 240V List Price \$6426 - **Our Price \$5783.40**

Prices Subject to Change
Email for exact pricing.



Oval Kilns



SKUTT KM 1627-3 PK

This kiln is big, powerful, and easy to use. With a 18.5 cubic foot firing chamber, it is ideal for large or irregularly shaped pieces, or large Production loads. Equipped with a KilnMaster controller, the 1627 PK fires to cone 10 and comes in 3 phase. This kiln is built with 3" brick, improving insulation and increasing energy efficiency. Dimensions: 46" x 30.75" x 27", 18.5 cubic feet.

KM 1627-3 PK, 208V & 240V 1 & 3 Ph LF

List Price \$10,745 **Our Price \$9670.50**

KM 1627-3 PK, 208V & 240V 3 Ph HF

List Price \$10,745- **Our Price \$9670.50**

NIDEC-SHIMPO OVAL KILN 4227

This kiln is durable and features a floor element and double-walled construction that eliminates cool spots in the firing chamber and increases energy efficiency. Fire to cone 10 and comes equipped with either a Bartlett Multi-Zone automatic controller or a Kiln Sitter with timer and switches. Dimensions: 41" x 31" x 27", 16.5 cubic feet.

With Kiln Sitter \$ Email for Pricing

With Bartlett Controller \$ Email for Pricing



Raku Kilns



LAGUNA RAKU KILNS

Laguna Raku kilns are safe, durable and easy to use. Three models range in size from 7.4 to 13.1 cubic feet, and each model can be used to fire to Cone 5 or even as a sculpture burnout oven. Laguna Raku kilns feature an easy-lift, counter-balanced firing chamber, heavy-gauge steel construction, and a one piece castable refractory floor. The firing chamber is lined with high-density fiber and the kiln is equipped with a water column gauge for accurate firing, and a 100% dual safety shut-off valve.

Model	Firing Area	Height	Diameter	Volume	Price
LE201RST Standard	23"		26"	7.4 cu ft.	Email
LE201RIN Intermediate	32"		26"	9.8 cu ft.	Email
LE201RSU Super	32"		30"	13.1cu ft.	Email

(All Raku Kilns require a Crating Charge of \$115.00)

Prices Subject to Change
Email for exact pricing.

Equipment & Firing Service

Equipment Repair

ClayPeople refers all repair work to Doc Peles at RJP Enterprises at 415-205-8402. Doc has more than 25 years of Ceramic Equipment Repair experience.

Firing Service

Firings are done by FULL Kiln, HALF Kiln or Single SHELF load. Half Kiln and Shelf Loads may have to wait for a full kiln for firing. All firing is first-come, first-served. Wait time may be up to two weeks or more for your firing to be completed, depending on the amount, temperature and what is in line already. Stilting is \$1/per piece, stilts NOT PROVIDED, please bring or purchase.

All items must be contained so we can move the work through our system. Your items will be loaded directly into the kiln from your container, and back into your container from the kiln. Once fired, we will call you for pickup. Please collect your work as soon as possible, as space is limited.

Payment is due prior to firing.

ClayPeople will not accept:

- Flammable or melt-able materials inside clay (e.g. paper clay, metal, decals)
- Glazed greenware
- Pieces that may explode during firing (e.g. hollow forms with no air hole, wet greenware)
- Pieces that contain questionable materials (e.g. unknown clay or glaze maturing temperature)

Kiln Size	Kiln	Low Fire- Bisque-Luster	Mid Fire
<i>*Max Size</i>		FULL KILN/HALF KILN/ SHELF	FULL KILN/HALF KILN/ SHELF
TEST - 11" x 13.5" .8cf	KM614-3	\$25/\$15/\$15	\$29/\$20 /\$20
LARGE - 23" x 24" 7 cf	KM1027	\$140/\$70/\$35	\$210/\$105/\$52
LARGEST - 28" x 29" 9.9 cf	KM1227	\$198/\$99/\$50	\$297/\$159/\$75



Terms & Conditions:

ClayPeople is not responsible for fired results or damage of any kind.

We reserve the right to refuse to fire any work.

Customer assumes full responsibility for the replacement/repair of any ClayPeople equipment damaged during firing, such as glaze running onto shelves.

WORK LEFT LONGER THAN 30 DAYS after firing will be discarded.

Kiln Controllers



Kiln firing controls allow you to control the firing temperature, as well as the heat ramp, making your electric kiln almost automatic.

KILNMASTER CONTROLLER

Made by Skutt. Wall mounted. Designed for easy use. Sealed touch pad protects controls. Single and grouped functions for easy use. Solid state circuitry for cone fire or ramp temperature, digital read-out, delayed start, adjustable alarm and cone table (converts cones to temperature). Can be used either 50 Amp or 3 Phase 40 Amp.

KMSTR 208-240V 50 Amp Wall **\$1065**
KMSTR3 208-240V 3 Phase 40 Amp Wall **\$1120**

SKUTT KILNLINK

KilnLink connects your kiln to the internet and feeds information from each firing in real time to the KilnLink Database. Authorized users just log on to their account using a computer or smart phone connected to the internet. You can even set it up to send you Email or Text alerts.

Required Hardware

KilnLink Box **\$400**
 EnviroLink **\$179.30**

Service Packages

1 Year Service **\$100**
 5 Years Service **\$325**

Prices Subject to Change
 Email for exact pricing.



Kiln Accessories

Venting Systems

SKUTT ENVIROVENT II

A downdraft ventilation system designed to extract fumes from your electric kiln and vent them outdoors before they have a chance to enter the room. It also improves the firing atmosphere in the kiln while it is protecting you from the odorous fumes that can be emitted from certain clay bodies and glazes when they are fired. Capable of venting two kilns simultaneously. Two-year limited warranty.



SKENV Envirovent2 Email for pricing
DUAL Exhaust Kit \$220.00
SK2477 8-ft. Extension Kit \$40.00
SK2500 Plenum cup \$52.00

SKUTT ENVIROLINK BOARD
ENVLINK \$190.00

ROLLING STAND ADAPTORS

8-Sided Kilns \$430
10-Sided Kilns \$450
12-Sided Kilns \$465
16-Sided Kilns \$580

RSADV Rolling Stand Adapt Envirovent \$35..00

Refractory Coatings & Cements

HIGH TEMPERATURE CAULK

High temperature (2300 F) caulk. For patching and insulating cracks, joints, and seams in high temperature kilns, furnaces, and glory holes.

CAULK 11.2 fl. oz. \$18.99



KAST-O-LITE 30

A castable refractory that is similar to concrete in mixing and workability. Designed to withstand temperatures up to 3000 degrees F.

KOL301 1 lb. \$2.99
KOL305 5 lbs. \$11.45
KOL3010 10 lbs. \$21.90
KOL3025 25 lbs. \$49.75
KOL3050 50 lbs. \$92.50

AIR SET MORTAR

A high temperature mortar which withstands heat up to 3000 F degrees.

HARP Pint \$8.75
HARQ Quart \$10.50
HARG Gallon \$30.00

SARISSET

Sairset has a maximum service temperature of 3,000 degrees F. Suitable for laying dense brick. Ideal as a general purpose refractory mortar.

SARISSET Sairset Refractory Mortar 2lbs \$7.99

Kiln Accessories

Brick

SOFT INSULATING BRICKS

Standard dimensions: 9" x 4-1/2" x 2-1/2". Can be special ordered at different dimensions.

Brick	Max Temp	
K23	2300F	\$6.99/ea.
K26	2600F	\$7.99/ea.



HARD FIRE BRICK

Most common sizes below. Other sizes available. Email for more information.

Brick	Dimensions	
Straights	9" x 4-1/2" x 2-1/2"	\$7.50
Soaps	9" x 2-1/4" x 2-1/2"	Email for price & availability



SKUTT KANTHAL ELEMENT PINS

12 per package. 1-1/4". SK1018 \$6.00/package.



INSWOOL INSULATING BLANKET

Revolutionary new insulating blanket. Works like Kaowool, but much safer to use. Fibers are dissolved by lung fluid and exit the body via the urinary tract. Not listed as a hazardous material in the U.S. 24" wide, 1" thick. Rated to 1800 degrees F.

Density 6 lbs. per ft. \$7.99



Wire

KANTHAL WIRE

For elements and for element staples. Will withstand temperature up to 2400 degrees F.



Gauge	Diam.	1-24 ft.
11	2.3 mm	1.72
12	2.1 mm	1.59
13	1.8 mm	1.39
14	1.6 mm	1.19
15	1.5 mm	1.05
16	1.3 mm	.93
17	1.2 mm	.90
18	1.0 mm	.80

KEMPER HIGH TEMP WIRE

Heat resistant to cone 5. 10 ft. per package. 17 gauge. KHTW \$7.85



We sell everything you need to fix a kiln or to build one of your own.

Prices Subject to Change
Email for exact pricing.

Kiln Parts - Skutt

Elements

CODE	Description	Each
SK0177	KM1018 2401P Ctr	65.00
SK0176	KM1018 240 1P TopBtm	65.00
SK0172	KM1027 240 1&3P Ctr	65.00
SK0171	KM1027 240 1&3P TopBtm	65.00
SK1376	KM1027-3 240 1&3P Ctr	65.00
SK1373	KM1027-3 240 1&3P TopBtm	65.00
SK1370	KM1227-3 240 1&3P Ctr	65.00
SK1368	KM 1227-3 240 1&3P TopBtm	65.00
SK1443	KM 1227-3 PK 240 1&3P Ctr	65.00
SK1442	KM 1227-3 PK 240 1&3P Inter	65.00
SK1441	KM 1227-3 PK 240 1&3P TopBtm	65.00
SK1541	KM 818 240 1P Ctr	55.00
SK1540	KM 818 240 1P TopBtm	55.00
SK1545	KM 818-3 240 1P Ctr	55.00
SK1544	KM 818-3 240 1P TopBtm	55.00
SK1018	PINS Pack of 12	6.00

Element Accessories

ELEMENT CONNECTORS

Crimp-on, set of 6
SK0074 \$19.00

ELEMENT PINS

Pack of 12
SK1018 \$4.50

FUSES AND FUSE HOLDERS

SK1921C FUSE .5
AMP \$2.00
SK1904C FUSE .5
AMP HOLDER \$9.00



KilnMaster Parts

ELEMENT FEEDER WIRE SETS

SK1585 Set 818 \$44.00
SK1584 Set 1018 \$44.00
SK1583 SET 1227/1027 \$59.00



HARNESS WIRE SETS

SK2564 Wiring Harn.
1018/818 1Ph \$37.00
SK2561 Wiring Harn.
1227/1027 1Ph \$48.00
SK2560 Wiring Harn.
1227/1027 3Ph \$45.00

TRANSFORMER

SK1518 \$45.00



RELAYS

SK2139
Relay 25amp Blk
(newer kilns) \$40.00



SK1517
Relay 25amp Clr
(older kilns) \$46.00



SK2083C
Relay 60amp Mercury
(newer kilns) \$90.00



SK2010C
Relay Pilot
All PK & KM1
Wall Mt \$14.00



Prices Subject to Change
Email for exact pricing.

Kiln Parts - Skutt

Kiln Bricks

CODE	Description	Each
SK0162	Kiln Brick Straight 10 sided	15.75
SK1407	Kiln Brick Straight 10 sided 3"	16.75
SK1400	Kiln Brick Straight 12 sided	16.75
SK1527	Kiln Brick Terminal 10 sided	16.25
SK1525	Kiln Brick Terminal 12 sided	17.25
SK1526	Kiln Brick Terminal 10 sided 3"	17.25
SK1532	Kiln Brick Thermocouple 12 sided	17.25
SK1527	Kiln Brick Terminal 10 sided	16.25
SK1534	Kiln Brick Thermocouple 10 sided	16.25
SK0164	Kiln Brick Thermocouple 10 sided	16.25



KilnSitter Parts

SHUT OFF TUBES

Crimp-on, set of 6
SK0074 \$19.00

SENSING RODS

SK0419D Sensing Rod 8" New Style \$12.00
SK1001D Sensing Rod 8.5" 3" brick \$12.00

GAUGE WASHER

SK0873 Gauge washer \$9.00

GUIDE PLATE WITH CLAW

SK0285 Guide plate for kiln sitter \$20.00

PROTECTIVE TUBES

PT Email for pricing.

CONE RESTS (PAIR)

SK0113 \$14.00



SHUT OFF TUBE ASSEMBLIES

SK0114 6" \$64.00
SK0339 7" \$64.00
SK0369 7.5" \$64.00

SWITCHES

SK0104 Switch 3 heat
1227/1027/1018+ \$85.00
SK0122 Switch block
Contact & Plunger \$100.00
SK0188R Switch infinite
120v-614 \$54.00
SK0874 Switch infinite
240v-818+ \$54.00

KILN TIMER MOTOR

SK0851 Kiln timer motor \$95.00

Kiln Hardware

LID BRACE ANCHOR PAD

SK0053 \$9.00

LID HANDLE OLD STYLE

SK0507C 1227-3 \$11.00

Pyrometric Cones

ORTON JR. SMALL CONES

Available individually, or boxes of 50. All temperature ranges available.

CMSI Individual Cones \$0.61/each
CSM Box of 50 \$11.80/box



ORTON JR. SMALL BARS

Available individually, or in boxes of 50. All temperature ranges available.

CBSMI Individual Bars \$0.71/each
CBSM Box of 50 \$13.80/box



ORTON STANDARD & SELF-SUPPORTING CONES

Available individually or in boxes of 50. All temperature ranges available.

CLGI Individual Standard Cones \$0.82/each
CLG Box of 50 \$16.00/box

CSELFI Indiv. Self-Supporting Cones \$1.94/each
CSELF Box of 25 \$11.80/box

ORTON STANDARD CONE PLAQUES

Holds large cones, two sizes.

Gas Kiln Plaque 4-holder \$2.79/each
Electric Kiln Plaque 3-holder \$2.75/each



Kiln Parts

Venturi Burners

MR750

The MR750 is an affordable and compact Venturi burner suitable for high fire kilns and furnaces or Raku kilns. It features flame retention within a one piece design. It is rated at approximately 78,000 BTUs for both propane and natural gas.
\$69.99



MR100

The MR100 is slightly larger than the MR750. It produces approximately 94,000 BTUs on propane and approximately 90,500 on natural gas.
\$79.00

Pyrometers & Thermocouples

SKUTT DIGITAL PYROMETER

Dual Input, Type K thermocouple, mounting block, 5 feet of thermocouple wire, pyrometer flange for mounting to the kiln. Case that can be mounted to the wall or it has a flip out back that can be set on a table. Remembers the minimum and maximum temperatures recorded in a firing. Rated to Cone 10, +/-0.4% of reading accuracy.
SK2783 \$160.00



THERMOCOUPLES

SK1913	Block	\$15.00
SK1515	Replace 6"	\$22.00
SK1516	Replace 8"	\$22.00
SK0021	12"	\$45.00

12" THERMOCOUPLE, BLOCK & WIRE

SK1506 \$42.00

TERMINAL BLOCKS

SK1906C	Term. Block 1P all KM	\$22.00
SK1925C	Term. Block 3P all KM	\$20.00
SK1519	Term. Strip Replace. w/ Tabs	\$32.00

Prices Subject to Change
 Email for exact pricing.

THERMOCOUPLE PROTECTOR TUBE (NOT PICTURED)

Extends the life of your thermocouple by covering the first 7". Inside dimension 5/8". Outside dimension 7/8". Big enough for 8 gauge thermocouple. Made of thin high temperature refractory material.

FS243 **\$38.99**

Peeps

PEEP HOLE PLUGS



PEEP1
 Skutt Ceramic
\$6.50



PEEP2
 Laguna
 Soft Brick
\$7.99

Rubbing Bricks

RUBBING BRICKS

These fluted, silicon carbide bricks are one of the most effective ways to clean glaze drips and excessive build up of kiln wash from kiln shelves. The brick is thick and long-lasting and is available with or without handle.

RUBB	Brick	8" x 2" x 2"	\$29.99
RUBBH	Brick w. Handle	1" x 3" x 6"	\$39.99



Kiln Furniture

Posts

TRI-POSTS 1.5 INCHES WIDE

CP#	MPN	Description	Each
.5P	RF30012	Tri Posts .5 in.	\$3.32
1	RF-301T	Tri Posts 1 in.	\$3.43
2	RF-302T	Tri Posts 2 in.	\$3.48
3	RF-303T	Tri Posts 3 in.	\$4.01
4	RF-304T	Tri Posts 4 in.	\$4.31
5	RF-305T	Tri Posts 5 in.	\$4.84
6	RF-306T	Tri Posts 6 in.	\$5.52
7	RF-307T	Tri Posts 7 in.	\$6.35
8	RF-308T	Tri Posts 8 in.	\$6.53
9	RF-309T	Tri Posts 9 in.	\$7.35
10	RF-310T	Tri Posts 10 in.	\$8.20
11	RF-311T	Tri Posts 11 in.	\$8.99
12	RF-312T	Tri Posts 12 in.	\$9.71
13	RF-313T	Tri Posts 13 in.	\$10.47
14	RF-314T	Tri Posts 14 in.	\$11.40
15	RF-315T	Tri Posts 15 in.	\$12.18

SQUARE POSTS 1 INCH WIDE

CP#	MPN	Description	Each
.5PS	RF30112	Square Sm Posts .5 in.	\$2.60
1S	RF-3011	Square Sm Posts 1 in.	\$2.75
2S	RF-3021	Square Sm Posts 2 in.	\$2.90
3S	RF-3031	Square Sm Posts 3 in.	\$3.20
4S	RF-3041	Square Sm Posts 4 in.	\$3.40
5S	RF-3051	Square Sm Posts 5 in.	\$3.75
6S	RF-3061	Square Sm Posts 6 in.	\$4.32
7S	RF-3071	Square Sm Posts 7 in.	\$4.93
8S	RF-3081	Square Sm Posts 8 in.	\$5.09
9S	RF-3091	Square Sm Posts 9 in.	\$5.72
10S	RF-3101	Square Sm Posts 10 in.	\$6.29

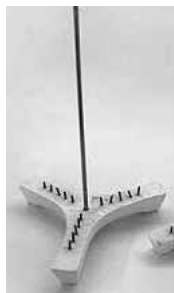

PERFUME STOPPER STILT

Equipped with a center pole for added strength. Ideal for stiling pixies, vases, etc.

FS832	1.5"	\$5.30
FS 836	2.5"	\$10.22

PLATE RACK

Unique plate rack enables the potter to fire from 1 to 6 plates in a stacking arrangement. Space-saving feature means using only as many as needed. Strong, sturdy and easy to use. Fire up to cone 5 only.

FS 219 \$12.99 set of 3



Stilts

FIRING STILTS

Tripod stilts. Double pointed. All ceramic materials. Fires to cone 10.



Code	Point to Point	Each	Dozen
FS 201	3/4"	2.72	27.15
FS 202	7/8"	2.76	27.57
FS 203	1"	3.03	30.32
FS 204	1-1/8"	3.10	31.04
FS 205	1-5/8"	3.39	33.93
FS 206	1-3/4"	3.80	38.04
FS 207	1-7/8"	4.15	41.51
FS 208	2"	4.86	48.60

TRIPOD STILTS WITH METAL WIRES

Fires to cone 5.

Code	Point to Point	Each	Dozen
FS 818		3.77	37.74
FS 811	1/2"	2.02	20.18
FS 801	3/4"	2.23	22.32
FS 802	1"	2.43	24.29
FS 803	1-1/2"	2.74	27.42
FS 804	2"	3.40	33.96
FS 805	1-1/2"	4.13	41.34
FS 806	2-1/4"	3.77	37.74
FS 808	2-3/4"	4.23	42.33
FS 810	3-1/2"	4.82	48.24

PYRAMID STILTS

Ceramic with one wire. Fires to cone 5. 3/4" high.

FS822	\$1.51 each	\$15.06 dozen
FS823	\$1.70 each	\$16.98 dozen

BAR STILTS

Fire to cone 5.

FS820	\$5.23 each	\$52.34 dozen
3 1/2" Ceramic bar with ten wires.		
FS 821	\$5.05	\$50.54 dozen
4" Ceramic bar		



STACKING TILE HOLDERS

Stackable and interlocking tile holders support the corners of your tiles and save spaces in your kiln. Accommodate any size tile.

Requires 4 holders per tile.

FS 220	\$7.27 set of 4
FS 220D	\$78.25 per dozen

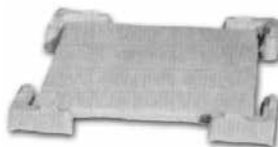

Kiln Furniture/Shelves

Kiln Furniture



BEAD TREE
A new concept in bead trees. Fires to cone 6. Uses shorter length rods.

BEAD \$21.95
Replacement rods (12)



LARGE BEAD RACK
Two durable stoneware supports with 6"-10" long wires. Fires to cone 6

RACK \$44.95
RODS \$29.95
Replacement rods (6)



6" X 6" TILE SETTER
Holds 11 tiles in a stack. Fires to cone 10.

TS6H \$69.95

CORELITE Kiln Shelves

Nearly half the weight of traditional kiln shelves and just as strong. Less likely to propagate cracks through their cores.

CODE	DIMENSIONS	KILN	PRICE
CL15R	15x 15 x 5/8	818, 818-3	\$28.35
CL15HR	15 x 7.5 x 5/8	818, 818-3	\$39.15
CL21R	21 x 5/8	1018,1022,1027	\$121.30
CL20R	20 x 5/8	1018-3,1022-3,1027-3	\$104.58
CL26HR58	25 1/2 x 12 x 5/8	1218-3,1222-3,1227-3	\$102.40
CL21HR	21 x 10 x 5/8	1018,1022,1027	\$73.11
C21HR	21 x 10 x 5/8	1018,1022,1027	\$210.05



NITRILE BONDED SILICON CARBIDE

SPECIAL ORDER ONLY

Nitride-Bonded Silicon Carbide Kiln shelves are light weight, offer exceptional strength at cone 11, and feature superior glaze release properties.



CODE	SIZE	PRICE
NB 12241	12" x 24" x 1"	\$146.50
NB 1128	11" x 28" x 5"	\$193
NB 1326	13" x 26" x 5"	\$199
NB 1428	14" x 28" x 5"	\$227
NB 1616	16" x 16" x .394"	\$155
NB 1818	18" x 18" x .394"	\$195
NB 21MSF	21" multi sided full	\$195
NB 21MSH	21" multi sided half	\$95
NB 26MSH	26" multi sided half	\$153
NB 1824	18" x 24" x .5"	\$273

* Please Email for Availability

Tile Setters

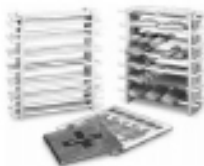

LAGUNA CONE 5 TILE SET RACK
Adjustable rack reduces mass of refractory material. Dims: 16" H x 10" w x 5"d
FS841E \$61.00

4" X 4" TILE SETTER

Holds 18 tiles. 9 side-by-side. Fires to cone 10.
TS4DH \$59.95

6" X 6" TILE SETTER

Holds 22 tiles. 11 side-by-side. Fires to cone 10.
TS6DH \$69.95



SILICON CARBIDE Kiln Shelves

SPECIAL ORDER ONLY

High refractory and super strong, these shelves are a must for firing consistently above cone 5 in a reduction atmosphere. Available in a variety of square and rectangular sizes.

CODE	SIZE	PRICE
SC161658	16x16x.625	\$140
SC182458	18x18x.625	\$289
SC182434	18x24x.75	\$339
SC142834	14x28x.75	\$299
SC162434L	16x24x.75	\$315
SC162434	16x24x.75	\$265
SC182434	18x24x.75	\$339



Kiln Shelves

LAGUNA Kiln Shelves

This kiln furniture is manufactured with superior quality body formulations, well-regulated quality control procedures, and a long and tightly controlled firing cycle. This results in a finished product composed of 50% cordierite and 35% mullite, with lesser amounts of corundum and other minerals. This combination yields excellent mechanical properties and a remarkably high resistance to thermal shock.

Prices Subject to Change

Email for exact pricing and availability.



AIM 88

Code	Dims	Price
7712	7" x 7" x 1/2"	\$10.52

SKUTT 614

Code	Dims	Price
HEX12F	9 1/4" x 12" x 1/2"	\$12.40
10R	10 3/8" Round	\$11.40
HEX12H	9 1/4" x 6" x 1/2"	\$9.10

SKUTT 714

Code	Dims	Price
13R	13" x 5/8" Round	\$22.93
13HR	13" x 5/8" Half Round	\$13.20

SKUTT 818

Code	Dims	Price
181	15" x 16" x 5/8" Octagon	\$28.35
181H	8" x 15" x 5/8" Half Oct.	\$18.28
CL15R	15" x 15" x 5/8" Corelite Round	\$74.51
CL15HR	15" x 7.5" x 5/8" Corelite Half	\$39.15

SKUTT 818-3

Code	Dims	Price
181S	15" x 15" x 5/8" Octagon	\$29.73
181H	8" x 15" x 5/8" Half Oct.	\$18.28
CL15R	15" x 5/8" Corelite Round	\$74.51
CL15HR	15" x 7.5" x 5/8" Corelite Half	\$39.15

SKUTT 1018, 1022, 1027

Code	Dims	Price
231F	21" x 22" x 5/8" Deca	\$56.75
19R	19" x 5/8" Round	\$52.28
231H	10 1/2" x 22" x 5/8" Half Deca.	\$26.32
19HR	19" x 5/8" Round	\$52.28
CL21R	21" x 5/8" Corelite Round	\$121.30
CL21HR	21" x 10" x 5/8" Corelite Half	\$73.11

SKUTT 1018-3, 1022-3, 1027-3

Code	Dims	Price
23GF	19" x 20" x 5/8" Deca	\$49.69
19R	19" x 5/8" Round	\$52.28
23GH	9 1/2" x 20" x 5/8" Half Deca.	\$25.15
19HR	19" x 5/8" Round	\$52.28
CL20R	20" x 5/8" Corelite Round	\$104.58
CL20HR	20" x 10" x 5/8" Corelite Half	\$62.51

SKUTT 1218-3, 1222-3, 1227-3

Code	Dims	Price
280	13" x 26" x 5/8" Half	\$38.69
CL26HR58	25 1/2" x 12" x 5/8" Corelite	\$102.40

Extruders

Scott Creek Extruders

SCOTT CREEK EXTRUDERS

Features a removable plunger for convenient loading, and a removable barrel cap for quick die changes. These extruders have unique cast aluminum inner die holders for greater diversity of hollow extrusions. Expansion boxes, which allow for larger extrusions, are available for the 4" and 5" models. A variety of optional die sets are also available.

4" STEEL EXTRUDER

Powder coated steel barrel model. Includes two blank dies.
SC007 \$452.00

4" ALUMINUM EXTRUDER

Scott Creek's most popular model. The aluminum barrel is removable from the back bar for easy cleaning. Includes 2 blank dies. **SC013 \$425.00**

5" ALUMINUM EXTRUDER

Scott Creek's largest extruder. Ruggedly built for heavy duty use. Includes two blank dies.
SC014 \$460.00

FLOOR MOUNT EXTRUDER STAND

SC038 \$711.00

TABLE MOUNT EXTRUDER STAND

SC037 \$232.00

HEAVY DUTY CLAY GUN & DIE KIT

Exceptionally handy, rugged extruder for making small runs of a particular form. You'll find many uses for this handy tool in your studio or classroom. Comes with a 1/2" coil die and two blank dies to customize to your own needs. Optional die kit includes 8 dies.

- SC001 Super Duper Clay Gun \$62.95**
- SC033 XL Clay Gun \$82.95**
- SC002 Clay Gun Die Kit \$21.95**
- SC008 Clay Gun Blank Die \$7.50**
- SC034 4" Clay Gun 8pc Handle Die Kit \$42.95**
- SC035 4" Clay Gun 8pc Shape & Coil Die Kit \$42.95**
- SC036 4" Clay Gun 8pc Tile & Trim Die Kit \$42.95**

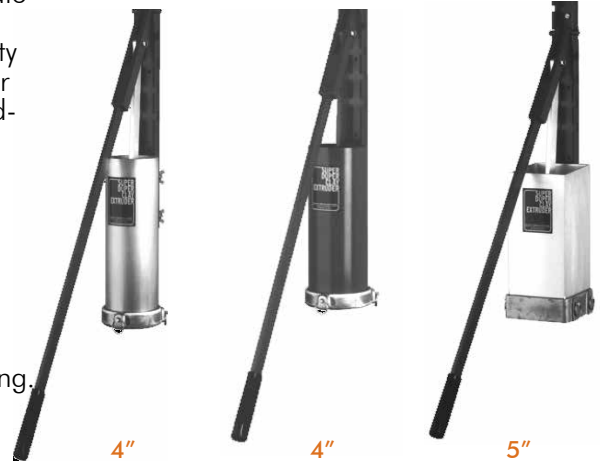

4" STEEL

4" ALUMINUM

5" ALUMINUM



SCOTT CREEK EXTRUDER ACCESSORIES

- SC003 4" Clay Gun 8pc Handle Die Kit \$51.95**
- SC004 4" Multi Shape Die \$51.95**
- SC007 4" Standard Clay Extruder \$452.00**
- SC008 4" Clay Gun Blank Die \$7.50**
- SC009 4" Extruder Die Kit (24 piece) \$141.95**
- SC010 4" Expansion Box \$262.00**
- SC011 4" Expansion Box Die Kit \$107.00**
- SC012 4" Expansion Slab Die Kit A \$92.00**
- SC013 4" Clay Extruder Aluminum \$425.00**
- SC014 5" Clay Extruder Aluminum \$460.00**
- SC015 5" Blank Aluminum Die \$8.00**
- SC016 5" Extruder Die Kit (6 piece) \$125.95**
- SC017 5" Expansion Box \$292.00**
- SC018 5" Expan. Box Die Kit, Wood \$107.00**
- SC021 4" Tile Cutter Square \$43.95**
- SC039 6" Tile Cutter Square \$65.95**

Extruders

North Star Extruders

NORTH STAR STAINLESS STEEL EXTRUDER

A simple, safe extruder for studio or school. Constructed from welded steel. Delivered complete with wall mounting hardware, basic dies, blank die, clay cutter and stainless steel die mask. The 4" barrel is tapered at the top for easy loading. Holds 5 - 8 lbs of clay. Tapered polyurethane dies for sharp extrusions are 1/2" thick.

NSEXTRUDER \$650.99

NORTH STAR REGULAR STEEL EXTRUDER

Same as stainless extruder, except that it is made of regular painted steel.
email for pricing

DIE SETS

Blank Extruder Dies (7)

\$104.95



Brent Extruders

BRENT HAND EXTRUDER

The hand extruder makes thousands of different solid or hollow shapes. Tubes, bars, tiles, slabs - the possibilities are endless. The barrel is 4" wide and holds 10 lbs. of clay. It comes with the hardware needed to be bolted to a wall or table, and an optional stand attaches it to the end of all Brent SR model slab rollers.



STANDARD SET

BE Heavy Duty set \$850.00

DIE SETS

BEHOLLOW Hollow Die Set

\$82.00

BESTD Standard Die Set

\$82.00



STANDS

Mount extruder on Brent Slab Rollers SR-14,20, & 36.

SC037 Table Mount

\$232.00

SC038 Floor Mount

\$711.00

Prices Subject to Change

Email for exact pricing and availability.

Slab Rollers

North Star Slab Rollers

STANDARD SLAB ROLLER PACKAGE

With canvas and wagon wheel handle only.

SLB24STDPKG 24" \$1323
SLB30STDPKG 30" \$1440



SUPER SLAB ROLLER PACKAGES

24", 30", or 36" Slab Roller with two 4" rolls. 72" steel work table, table top, canvas, hardware, and wagon wheel handle.

SLB24SUPPKG 24" \$1898
SLB30SUPPKG 30" \$2369
SLB36SUPPKG 36" \$2944

Extra Canvas Sets, 21 oz. duck, for 24" or 30" Standard or Super Slab Rollers.

CAN18PORT \$35.00
CAN24STD \$38.00
CAN30STD \$44.00
CAN24SUP \$58.00
CAN30SUP \$65.00
CAN36SUP \$72.00

PORTAROLLER

Designed for ceramic arts teachers who are moving from classroom to classroom and for studio potters who need a fully functional slab roller but have limited space. The PortaRoller has two rolls, much like the wringer of an old-fashioned washing machine. Slab thickness infinitely variable from 0 to 2-3/4 inches. Slabs can be rolled in either direction and clay can be added or subtracted at any time. Roll slabs up to 16" wide.

SLB18PORT \$840



Prices Subject to Change

Email for exact pricing and availability.

Slab Rollers

Nidec-Shimpo Slab Roller

NIDEC-SHIMPO SLAB ROLLER

Heavy-duty slab roller produces up to a 3" thick slab. Two-roller system reduces warping. Synchronized adjustment allows for control of slab thickness. Wagon wheel handle provides easy feeding of slab through rollers in either direction. 30"x 50" table. Comes with one canvas set.
SR3050 \$1212.00

NIDEC-SHIMPO SLAB ROLLER MINI

Recommended for small studio space, maintenance free, portable and easy to store when not in use. Dimensions 16" x 24"
SRM1624 \$690.00

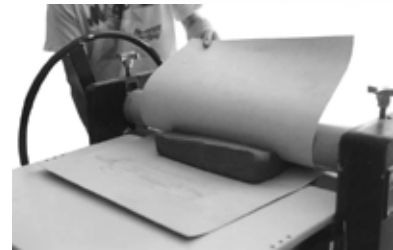

SLAB MATS

Get smooth slabs without canvas texture. Slab Mat is a non-woven material for slab-rollers, tabletop slab rolling and hand building.

SLBMT1416 14" x 16" - \$ 7.99

SLBMT1460 14" x 60" - \$22.99

SLBMT1622 16" x 22" - \$12.99

SLBMT2260 22" x 60" - \$31.99

Good for a 24" slab roller

SLBMT3044 30" x 44" - \$31.99

SLBMT3060 30" x 60" - \$49.99

Good for a wider slab roller

SLBMT1214 12" x 14" - \$5.99

Brent Slab Rollers

SR-20

Rolls slabs 20" wide by 5' long. Comes with steel pipe legs and three masonite shims: one 1/8" plain and two 1/4" with canvas.

SR-36

Rolls slabs 36" wide by 5' long, 1/8" to 1-1/4" thick. Comes with steel pipe legs and four masonite shims: one 1/8" plain, one 1/4" plain and two 1/4" with canvas.



Special Order

Email for exact pricing and availability.

SRC

Practical for home and studio use, the SRC can produce slabs 21" wide and 40" long, from 1/4" to 1" thick. Each SRC comes with six masonite shims: four 1/4" plain, one 1/4" with canvas and one 1/8" plain. Available as either a table model or with easy-to-assemble screw-in-legs.

SR-14

Rolls out slabs 14" wide and 3' long. Includes three masonite shims: one 1/8" plain and two 1/4" with canvas. Can be used on a table or mounted on the optional leg set.

ACCESSORIES

Leg Set for SR-14

Leg Set for SRC

Shims and top canvases are available for all models. Email for pricing.

Pug Mills & Clay Mixers

Nidec-Shimpo Pug Mills

Prices Subject to Change

Email for pricing and availability.

NIDEC-SHIMPO PUG MILLS

Die cast body is corrosion resistant. Twin mixing augers are die-cast aluminum with stainless steel cores. Augers, plates and other parts are removeable for easy cleaning. Dual safety system automatically shuts off machine when augers are exposed.

One year warranty.

NRA-04 - 1/4 HP, 880lbs./hour, 3-1/2" round nozzle

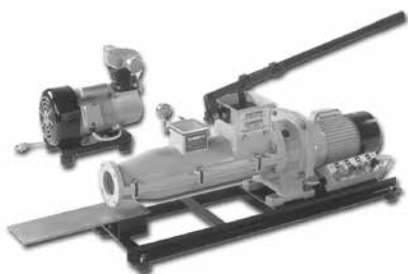

ADD-A-VAC PUG MILL

New Nidec-Shimpo pug mill. Buy a complete unit with vacuum or buy the basic pugmill now and upgrade to de-airing later - the vacuum unit is compact and easy to attach. Features a 1 HP motor, 800 lbs./hour extruding capacity, 3" nozzle, aluminum barrel, heavy duty construction and numerous safety features.

PM-071 without vacuum pump

PM-071V with vacuum pump

Venco Pug Mills

VENCO PUG MILLS

Industrial quality pugmills built to meet the most demanding studio pugging requirements. Models supplied with high horsepower motor, heavy duty in-line gearbox, stainless mixing blades, and auger. The cast aluminum barrel splits longitudinally for easy cleaning.



NON-DE-AIRING

NL-330: 3" nozzle

1/2 HP motor, 500 lbs./hour output

DE-AIRING

NL-331: 3" Nozzle

1/2 HP, 400 lbs./hour

NL-332: 3.5" Nozzle

1 HP, 800 lbs./hour

NL-333: 4" Nozzle

2 HP, 1200 lbs./hour

Email for pricing & availability.

PETER PUGGER

The complete clay processing machine. Features batch mixing, push button controls, a high quality, heavy duty drive, a large hopper, and stainless steel construction. We feature both non-deairing (PM) and deairing (VPM) models.

The PM-50 pugs 1200 lbs/hr., the PM-100 pugs 2000 lbs./hr., the VPM-9 pugs 500 lbs./hr., the VPM-20 pugs 600 lbs./hr., the VPM-30 pugs 800 lbs./hr., and the VPM-60 pugs 1500 lbs./hr.

PM-50

PM-100

VPM-9

VPM-20

VPM-20ss

VPM-30

VPM-60



Ware Carts



BRENT WARE CART EX

Nine shelf supports. Constructed from 1" steel pipe and welded shelf supports, it is 78" high, 35" wide, and 24" deep. The 4" rubber swivel casters roll easily when cart is loaded and can be firmly locked in place when needed. Twelve 12" x 32" x 1/2" thick exterior plywood shelves offer strength and dozens of stacking options.

BWC Cart w/shelves and cover **\$1040.00**

Set of 12

BWCS Shelf set **\$180**



LAGUNA WARE CART

This sturdy ware cart features all steel construction and 4" diameter hard rubber casters with a convenient 18 shelf capacity. Measuring 24" x 38" x 58", the cart assembles very easily and will ship UPS. Includes 6 exterior grade plywood shelves.

LWC Ware Cart **\$425**

LWCS Additional Shelves
\$5.95/ea.



BRENT BATMOBILE

42" high x 35" long x 14" wide. The batmobile can hold 60 to 90 bats, depending on the thickness. Has an adjustable shelf to accommodate 12" and 14" bats. The top shelf can be used as a ware cart.

BBM **\$718**



NORTHSTAR WARE CART

Constructed of 14 gauge steel with 6" industrial casters, two of which have parking brakes. The use of shelf brackets allows flexibility of shelf placement. Up to 22 shelves for holding tile.

Prices Subject to Change

Email for exact pricing and availability.

Books & Periodicals

Books

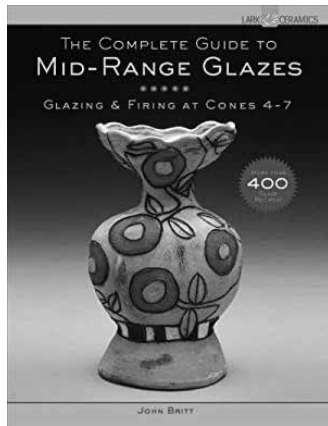

**COMPLETE GUIDE TO
MID-RANGE GLAZES**
BRITT5 \$29.95

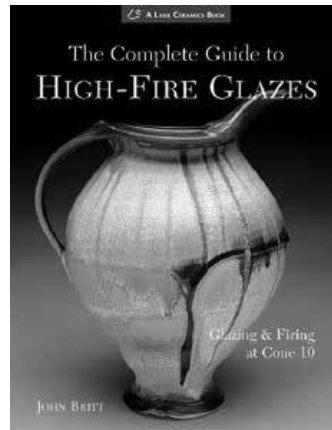

**COMPLETE GUIDE TO
HIGH-FIRE GLAZES**
BRITT10 \$17.95



CUSHING'S HANDBOOK
CUSHING \$45.99



HANDMADE TILE
HANDMADE \$35.00

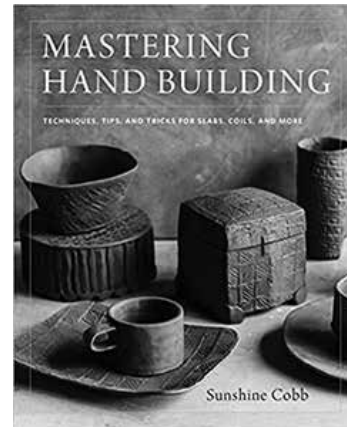

MASTERING HAND BUILDING
MASTERING \$32.00

Periodicals

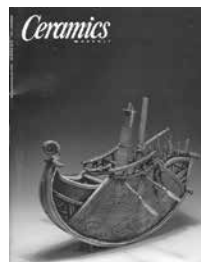

CERAMICS MONTHLY
\$7.50



POTTERY MAKING ILLUSTRATED
\$6.00

Index

A

Adhesives	34
AMACO Velvet Underglazes	53
Apron	31
APT II	34
Aztec High Fire Mender	34

B

Bamboo Sculpture Tool Set	18
Banding Wheels	59
Batmobile	91
Bat pins	70
Bats	70
Bead Rack & Tree	804
Bisque Tile	34
Books & Periodicals	92
Brent Electric Wheels	69
Brushes	28-29
Burners	82

C

Calipers	17
Canvas	88
Carts	91
Casting Slips	10
Caulk	74
Chamois	27
Clay	4-7
Clay Guns	86
Clay Mixers	90
Clay Shapers	17
Clay Pricing	8-10
Coleman Dry Showcase Glazes	57
Cones	81
Contact Information	1
Containers	32
Contents	1
Corks	34

D

Darvan #7	10
Delivery	3
Diapads	32
Dipping Tongs	33
Directions	2
Dry Glazes	57
Dry Slip Pricing	10
Duncan Discovery Brushes	28

E

E6000 Industrial Adhesive	34
Elements	80
Element Pins	80
Equipment Service	76
Extruders	87

F

Fiber Blanket	79
Fiber Rope	79
Firing Service	76
Firing Stilts	83
Frits	62
Funnels	32

G

Giffin Grip	70
Gift Cards	3
Glaze Products	35-57
Glazes	
Dry Glazes	56, 57
Laguna Dry Raku Glazes	56,57
High Fire Glazes	
Spectrum High Fire Glazes	50
Tom Coleman Dry Showcase Glazes ..	57
Low Fire Glazes	36
Amaco Teacher's Palette	35
Amaco Opalescent	38
Amaco Crystaltex	36
Laguna Lead Free Low Fire	39
Leslie's N-Series	38
Leslie's Lava and Crackle	39
Mid Fire Glazes	
Amaco Potter's Choice	39
Amaco Celadon & Satin Matte	41
Amaco HF Series	41
Coyote Mid Fire Glazes	45
Georgie's Glazes	42
Laguna Crystal Blossom Glazes	45
Laguna Moroccan Sand Glazes	46
Laguna Mystic Glazes	45
Leslie's Koke and Niji	40
Spectrum Stoneware Glazes	48
Raku Glazes	57
Multi-Cone Glazes	47-49
Gleco Trap	33
Gloves	31
Grinding Disks	70

H

Handles	34
High Fire Stoneware	6,9

Index

Hole Cleaners.....	27
Hydrometers.....	32

I

Insulating Blanket.....	79
ITC Ceramic Coating.....	78

J

Jiffy Mixing Wands.....	32
-------------------------	----

K

Kanthal Wire.....	79
Kaowool.....	31
Kemper Tools.....	11
Kickwheel.....	68
KilnMaster.....	77
KilnMaster Parts.....	80

Kilns.....	72-76
LKiln Accessories.....	78-85
Kiln EnviroVents.....	78

L

Leg Extension Kit.....	71
Low Fire Clay.....	4,8
Lusters.....	56

M

Magic Mender.....	34
Mallets and Paddles.....	24
Mason Stains®.....	65-67
Medium Fire Clay.....	5,8
Mid Fire Glazes.....	40
Mixing Paddle.....	25
MKM Decorating Disks.....	25
MKM Paddles.....	25
MKM Rollers.....	26
MKM Ribs.....	22
Mold Making Supplies.....	58
Mold Notches.....	58
Mouth Sprayers.....	30

O

Overglaze.....	56
----------------	----

P

Patch Attach.....	34
Peep Hole Plugs.....	82
Periodicals.....	92
Peter Pegger.....	90

Plaster, Additive and Pricing.....	60
Plaster Rasps.....	21
Porcelain.....	7,10
Portaroller.....	88
Posts.....	83
Pot Lifts.....	20
Potter's Pads.....	55
Potter's Wheels.....	68-69
Precious Metals.....	52
Pug Mills.....	90
Putty Knife.....	15
Pyrometers.....	82

R

Raku Kilns.....	75
Raku Glaze.....	53
Raku Tongs.....	33
Raw Materials.....	61-63
Refractory Coatings & Cements.....	78
Repair Service.....	3,76
Respirator.....	31
Ribs.....	22,23
Rollers.....	24,26
Rose Cutter Set.....	20
Rubber Bands.....	58
Rubbing Bricks.....	82

S

Safety Equipment.....	31
Safety Glasses.....	31
Sanding Pads.....	27
Scales.....	30
Scoops.....	32
Shelves, kiln.....	84-85
Nidec-Shimpo Wheels.....	68
Shipping.....	3
Sieves.....	33
Silicon Carbide Kiln Shelves.....	84
Skutt Kilns.....	71-75
Slab Mat.....	83
Slab Rollers.....	89
Slip Additives.....	10
Slips.....	10
Slip Trailers & Decorators.....	19
Sodium Silicate.....	10
Spectrum Glazes.....	37,42,43,46,50
Splash Pan.....	71
Sponges.....	27
Spout Maker.....	15
Spray Bottle.....	30
Sprayers.....	30
Spray Sealers.....	34
Squeegee.....	27
Stains, Mason.....	65-67
Stamps.....	20,25
Stilt Mark Stones.....	32
Stilts.....	83

Index

Stools 71

T

Tea Pot Handles 34
Textured Block Set..... 20
Texture Mats..... 20
Thermocouples 782
Throwing Bucket..... 71
Throwing Tools 18
Tile Cutters 20
Tiles 34
Tile Setters 84
Tom Coleman Glazes 57
Tongs 33
Tools 11-25
Tool Kit..... 15
Tri-Posts 83
Turntables 59

U

Underglaze Chalk 55
Underglaze Marker..... 55
Underglaze Pencils Amaco 55
Underglaze Pencils Choxil 55
Underglazes..... 50-55
 AMACO Velvet Underglazes..... 53
 Coyote High Fire Underglazes 50
 Speedball Underglazes 52
Underglaze Watercolor Paint Sets..... 54

V

Van Gilder Tools..... 16,23
Venting Systems..... 78
Venturi Burners 82
Viscometer..... 9

W

Ware Carts 93
Water Buffalo Horn Tools 18
Watercolor Paint Sets 54
Wax Resist..... 56
Website 3
Wet Slip Pricing 10
Wheel Leg Extensions..... 71
Wheels 68-71
 Brent Electric Wheels 69
 Laguna Kickwheel..... 68
 Pacifica Electric Wheels..... 69

Nidec-Shimpo Whisper Wheels..... 69
Wire, Kanthal..... 79
Wire Clay Cutters 16

X

XL Plus..... 78